

CITY LINE

world wide seals



INDEX



| Table of Materials DIN 24960 | | | | | | | | | |
|---------------------------------|----|---------------------------------|----|----------------------|----|-----------------|----|-----------------|----|
| Primary Rings | | Mating Rings | | Secondary seals | | Springs | | Metal parts | |
| Sintered silicon carbide | Q | Ceramic | V1 | NBR | P | Stainless 304 | F1 | Stainless 304 | F1 |
| Reaction bonded silicon carbide | Q1 | Sintered silicon carbide | Q | Viton | V | Stainless 316 | G | Stainless 316 | G |
| Tungsten carbide | U | Reaction bonded silicon carbide | Q1 | Food Compliant Viton | V3 | Hastelloy | M | Hastelloy | M |
| Phenolic graphite | B | Tungsten carbide | U | EPDM | E | Stainless Steel | F | Stainless Steel | F |
| Carbon - double resin impreg | B1 | Carbon - double resin impreg | B1 | PTFE | T | | | | |
| Carbon - Furan resin impreg | B2 | Carbon - Furan resin impreg | B2 | Aflas | K | | | | |
| Carbon - Antimony impreg | A | Carbon - Antimony impreg | A | | | | | | |
| Graphite filled silicon carbide | Q4 | Graphite filled silicon carbide | Q4 | | | | | | |
| Example | | | | | | | | | |
| Q1 | | B1 | | V | | M | | F1 | |
| Primary Rings | | Mating Rings | | Secondary seals | | Springs | | Metal parts | |
| Reaction bonded silicon carbide | | Carbon - double resin impreg | | Viton | | Hastelloy | | Stainless 304 | |

New York Elastomer bellows seals

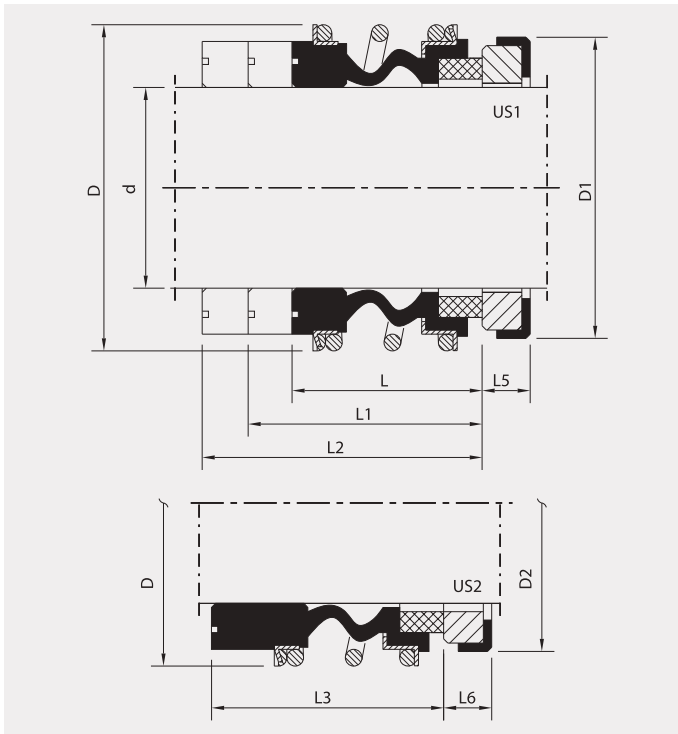

| | NY1 | NY2 | NY3 | NY4 | US1 | | US2 | | |
|-----|-------|------|------|------|------|-------|------|-------|------|
| d | D | L | L1 | L2 | L3 | D1 | L5 | D2 | L6 |
| 10 | 22.5 | 14.5 | 25.9 | 33.4 | 25.0 | 21.0 | 6.6 | 24.6 | 9.0 |
| 12 | 25.0 | 15.0 | 25.9 | 33.4 | 25.0 | 23.0 | 6.6 | 27.8 | 9.0 |
| 14 | 28.5 | 17.0 | 28.4 | 33.4 | 25.0 | 25.0 | 6.6 | 31.0 | 10.5 |
| 15 | 28.5 | 17.0 | 28.4 | 33.4 | 25.0 | 27.0 | 6.6 | 31.0 | 10.5 |
| 16 | 28.5 | 17.0 | 28.4 | 33.4 | 25.0 | 27.0 | 6.6 | 31.0 | 10.5 |
| 18 | 32.0 | 19.5 | 30.0 | 37.5 | 25.0 | 33.0 | 7.5 | 34.2 | 10.5 |
| 20 | 37.0 | 21.5 | 30.0 | 37.5 | 25.0 | 35.0 | 7.5 | 35.7 | 10.5 |
| 22 | 37.0 | 21.5 | 30.0 | 37.5 | 25.0 | 37.0 | 7.5 | 37.3 | 10.5 |
| 24 | 42.5 | 22.5 | 32.5 | 42.5 | 25.0 | 39.0 | 7.5 | 40.5 | 10.5 |
| 25 | 42.5 | 23.0 | 32.5 | 42.5 | 25.0 | 40.0 | 7.5 | 40.5 | 10.5 |
| 28 | 49.0 | 26.5 | 35.0 | 42.5 | 33.0 | 43.0 | 7.5 | 47.7 | 12.0 |
| 30 | 49.0 | 26.5 | 35.0 | 42.5 | 33.0 | 45.0 | 7.5 | 50.8 | 12.0 |
| 32 | 53.5 | 27.5 | 35.0 | 47.5 | 33.0 | 48.0 | 7.5 | 50.8 | 12.0 |
| 33 | 53.5 | 27.5 | 35.0 | 47.5 | 33.0 | 48.0 | 7.5 | 54.0 | 12.0 |
| 35 | 57.0 | 28.5 | 35.0 | 47.5 | 33.0 | 50.0 | 7.5 | 54.0 | 12.0 |
| 38 | 59.0 | 30.0 | 36.0 | 46.0 | 33.0 | 56.0 | 9.0 | 57.2 | 12.0 |
| 40 | 62.0 | 30.0 | 36.0 | 46.0 | 33.0 | 58.0 | 9.0 | 60.4 | 12.0 |
| 42 | 65.5 | 30.0 | 36.0 | 51.0 | 41.0 | 61.0 | 9.0 | 63.5 | 12.0 |
| 43 | 65.5 | 30.0 | 36.0 | 51.0 | 41.0 | 61.0 | 9.0 | 63.5 | 12.0 |
| 45 | 68.0 | 30.0 | 36.0 | 51.0 | 41.0 | 63.0 | 9.0 | 63.5 | 12.0 |
| 48 | 70.5 | 30.5 | 36.0 | 51.0 | 41.0 | 66.0 | 9.0 | 66.7 | 12.0 |
| 50 | 74.0 | 30.5 | 38.0 | 50.5 | 41.0 | 70.0 | 9.5 | 69.9 | 13.5 |
| 53 | 78.5 | 33.0 | 36.5 | 59.0 | 41.0 | 73.0 | 11.0 | 73.1 | 13.5 |
| 55 | 81.0 | 35.0 | 36.5 | 59.0 | 41.0 | 75.0 | 11.0 | 76.2 | 13.5 |
| 58 | 85.5 | 37.0 | 41.5 | 59.0 | 41.0 | 78.0 | 11.0 | 79.4 | 13.5 |
| 60 | 88.5 | 38.0 | 41.5 | 59.0 | 41.0 | 80.0 | 11.0 | 79.4 | 13.5 |
| 65 | 93.5 | 40.0 | 41.5 | 69.0 | 49.0 | 85.0 | 11.0 | 92.1 | 16.0 |
| 68 | 96.5 | 40.0 | 41.5 | 68.7 | 49.0 | 90.0 | 11.3 | 95.3 | 16.0 |
| 70 | 99.5 | 40.0 | 48.7 | 68.7 | 49.0 | 92.0 | 11.3 | 95.3 | 16.0 |
| 75 | 107.0 | 40.0 | 48.7 | 68.7 | 52.0 | 97.0 | 11.3 | 101.6 | 16.0 |
| 80 | 112.0 | 40.0 | 48.0 | 78.0 | 56.0 | 105.0 | 12.0 | 114.3 | 20.0 |
| 85 | 120.0 | 41.0 | 46.0 | 76.0 | 56.0 | 110.0 | 14.0 | 117.5 | 20.0 |
| 90 | 127.0 | 45.0 | 51.0 | 76.0 | 59.0 | 115.0 | 14.0 | 123.9 | 20.0 |
| 95 | 132.0 | 46.0 | 51.0 | 76.0 | 59.0 | 120.0 | 14.0 | 127.0 | 20.0 |
| 100 | 137.0 | 47.0 | 51.0 | 76.0 | 62.0 | 125.0 | 14.0 | 133.4 | 20.0 |

Technical features

- Single seal
- Unbalanced
- Spring enclosed
- Elastomer bellows

Operating limits

P = 174 PSI
T = -95 to 320°F
V = 32 ft/s

| Description | Materials |
|-----------------|--|
| Primary rings | silicon carbide, tungsten carbide, carbon graphite |
| Mating rings | silicon carbide, ceramic, carbon graphite, stainless |
| Secondary seals | NBR, EPDM, Viton |
| Metal parts | Stainless 304 / Stainless 316* |

* upon request

Available products:

- New York 1 (NY1)
- New York 2 (NY2)
- New York 3 (NY3)
- New York 4 (NY4)

Mating rings

- US1 (to DIN 24960, standard for NY1, NY2, NY3)
- US2 (standard for NY4)
- US5, US6, US7 (to DIN 24960)
- US3

For more details on mating rings see page 29

Chicago

Elastomer bellows seals

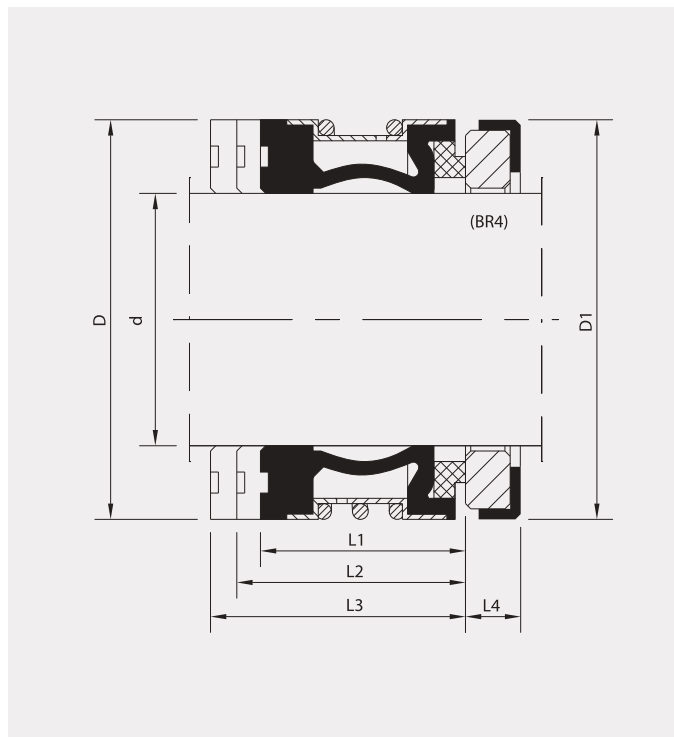

Technical features

- Single seal
- Unbalanced
- Single spring
- Elastomer bellows
- Bayonet drive
- To DIN 24960

Operating limits

P = 261 PSI
 T = -95 to 320°F
 V = 49 ft/s

| Description | Materials |
|-----------------|--|
| Primary rings | silicon carbide, tungsten carbide, carbon graphite, graphite filled sic. |
| Mating rings | silicon carbide, ceramic, tungsten carbide |
| Secondary seals | Neoprene, NBR, EPDM, Viton |
| Metal parts | Stainless 304 / Stainless 316* |

*upon request

Available products:

Metric size

- Chicago 1 (CG1)
- Chicago 2 (CG2)
- Chicago 3 (CG3)

Imperial size

- Chicago 4 (CG4)
- Chicago 5 (CG5)
- Chicago 6 (CG6)

Mating rings

- BR2 (standard)
- BR4 (for CG1, CG2, CG3)
- FR1 (for CG4, CG5, CG6)

For more details on mating rings see page 29

| | | CG1 | CG2 | CG3 | BR4 | | CG4 *CG5 CG6 | | | | |
|-----|-----|-----|------|------|-----|------|--------------|-------|-------|-------|------|
| d | D | L1 | L2 | L3 | D1 | L4 | d | D | L1 | L2 | L3 |
| 10 | 20 | 15 | 27.5 | 35 | 21 | 5 | .500 | .945 | .591 | .812 | .656 |
| 12 | 22 | 15 | 26.5 | 34 | 23 | 6 | .625 | 1.024 | .591 | .875 | .718 |
| 14 | 24 | 15 | 29 | 34 | 25 | 6 | .750 | 1.260 | .787 | .875 | .718 |
| 15 | 25 | 15 | 29 | 34 | 26 | 6 | .875 | 1.417 | .787 | .937 | - |
| 16 | 26 | 15 | 29 | 34 | 27 | 6 | 1.000 | 1.535 | .787 | 1.000 | .812 |
| 18 | 32 | 20 | 31.5 | 39 | 33 | 6 | 1.125 | 1.654 | 1.024 | 1.062 | - |
| 20 | 34 | 20 | 31.5 | 39 | 35 | 6 | 1.250 | 1.811 | 1.024 | 1.062 | - |
| 22 | 36 | 20 | 31.5 | 39 | 37 | 6 | 1.375 | 1.929 | 1.024 | 1.125 | - |
| 24 | 38 | 20 | 34 | 44 | 39 | 6 | 1.500 | 2.126 | 1.181 | 1.187 | - |
| 25 | 39 | 20 | 34 | 44 | 40 | 6 | 1.625 | 2.205 | 1.181 | 1.375 | - |
| 28 | 42 | 26 | 36.5 | 44 | 43 | 6 | 1.750 | 2.402 | 1.181 | 1.375 | - |
| 30 | 44 | 26 | 35.5 | 43 | 45 | 7 | 1.875 | 2.520 | 1.181 | 1.500 | - |
| 32 | 46 | 26 | 35.5 | 48 | 48 | 7 | 2.000 | 2.598 | 1.181 | 1.500 | - |
| 33 | 47 | 26 | 35.5 | 48 | 48 | 7 | 2.125 | 2.717 | 1.181 | 1.687 | - |
| 35 | 49 | 26 | 34.5 | 47 | 50 | 8 | 2.250 | 3.031 | 1.299 | 1.687 | - |
| 38 | 54 | 30 | 37 | 47 | 56 | 8 | 2.375 | 3.150 | 1.299 | 1.812 | - |
| 40 | 56 | 30 | 37 | 47 | 58 | 8 | 2.500 | 3.268 | 1.299 | 1.812 | - |
| 43 | 59 | 30 | 37 | 52 | 61 | 8 | 2.625 | 3.465 | 1.299 | 1.937 | - |
| 45 | 61 | 30 | 37 | 52 | 63 | 8 | 2.750 | 3.504 | 1.299 | 1.937 | - |
| 48 | 64 | 30 | 35 | 50 | 66 | 10 | 2.875 | 3.780 | 1.299 | 2.062 | - |
| 50 | 66 | 30 | 37.5 | 50 | 70 | 10 | 3.000 | 3.898 | 1.575 | 2.062 | - |
| 53 | 69 | 30 | 37.5 | 60 | 73 | 10 | | | | | |
| 55 | 71 | 30 | 37.5 | 60 | 75 | 10 | | | | | |
| 58 | 78 | 33 | 42.5 | 60 | 78 | 10 | | | | | |
| 60 | 80 | 33 | 40.5 | 58 | 80 | 12 | | | | | |
| 63 | 83 | 33 | 40.5 | 58 | 83 | 12 | | | | | |
| 65 | 85 | 33 | 40.5 | 68 | 85 | 12 | | | | | |
| 68 | 88 | 33 | 40.5 | 68 | 90 | 12 | | | | | |
| 70 | 90 | 33 | 48 | 68 | 92 | 12 | | | | | |
| 75 | 99 | 40 | 48 | 68 | 97 | 12 | | | | | |
| 80 | 104 | 40 | 47.5 | 77.5 | 105 | 12.5 | | | | | |
| 85 | 109 | 40 | 47.5 | 77.5 | 110 | 12.5 | | | | | |
| 90 | 114 | 40 | 52.5 | 77.5 | 115 | 12.5 | | | | | |
| 95 | 119 | 40 | 52.5 | 77.5 | 120 | 12.5 | | | | | |
| 100 | 124 | 40 | 52.5 | 77.5 | 125 | 12.5 | | | | | |

Madrid

Elastomer bellows seals

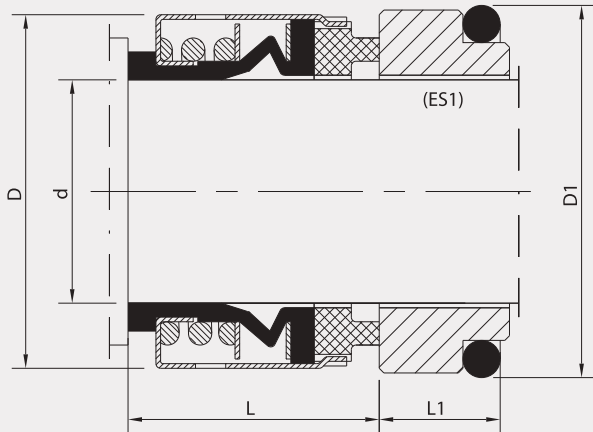

Technical features

- Single seal
- Single spring
- Unbalanced
- Bi-directional
- Elastomer bellows
- To DIN 24960

Operating limits

P = 580 PSI
 T = -95 to 320°F
 V = 49 ft/s

| Description | Materials |
|-----------------|--|
| Primary rings | silicon carbide, carbon graphite, tungsten carbide |
| Mating rings | silicon carbide, ceramic, tungsten carbide |
| Secondary seals | NBR, EPDM, Viton |
| Metal parts | Stainless 304 / Stainless 316* |

* upon request

Mating rings

- ES1 (to DIN 24960)

| d | MD | | ES1 | |
|-----|-----|------|-------|------|
| | D | L | D1 | L1 |
| 14 | 24 | 23.0 | 25.0 | 12.0 |
| 16 | 26 | 23.0 | 27.0 | 12.0 |
| 18 | 32 | 24.0 | 33.0 | 13.5 |
| 20 | 34 | 24.0 | 35.0 | 13.5 |
| 22 | 36 | 24.0 | 37.0 | 13.5 |
| 24 | 38 | 26.7 | 39.0 | 13.5 |
| 25 | 39 | 27.0 | 40.0 | 13.0 |
| 28 | 42 | 30.0 | 43.0 | 12.5 |
| 30 | 44 | 30.5 | 45.0 | 12.0 |
| 32 | 46 | 30.5 | 48.0 | 12.0 |
| 33 | 47 | 30.5 | 48.0 | 12.0 |
| 35 | 49 | 30.5 | 50.0 | 12.0 |
| 38 | 54 | 32.0 | 56.0 | 13.0 |
| 40 | 56 | 32.0 | 58.0 | 13.0 |
| 43 | 59 | 32.0 | 61.0 | 13.0 |
| 45 | 61 | 32.0 | 63.0 | 13.0 |
| 48 | 64 | 32.0 | 66.0 | 13.0 |
| 50 | 66 | 34.0 | 70.0 | 13.5 |
| 53 | 69 | 34.0 | 73.0 | 13.5 |
| 55 | 71 | 34.0 | 75.0 | 13.5 |
| 58 | 78 | 39.0 | 78.0 | 13.5 |
| 60 | 80 | 39.0 | 80.0 | 13.5 |
| 63 | 83 | 39.0 | 83.0 | 13.5 |
| 65 | 85 | 39.0 | 85.0 | 13.5 |
| 68 | 88 | 39.0 | 90.0 | 13.5 |
| 70 | 90 | 45.5 | 92.0 | 14.5 |
| 75 | 95 | 45.5 | 97.0 | 14.5 |
| 80 | 104 | 45.0 | 105.0 | 15.0 |
| 85 | 109 | 45.0 | 110.0 | 15.0 |
| 90 | 110 | 50.0 | 115.0 | 15.0 |
| 95 | 119 | 50.0 | 120.0 | 15.0 |
| 100 | 124 | 50.0 | 125.0 | 15.0 |

Miami

Elastomer bellows seals

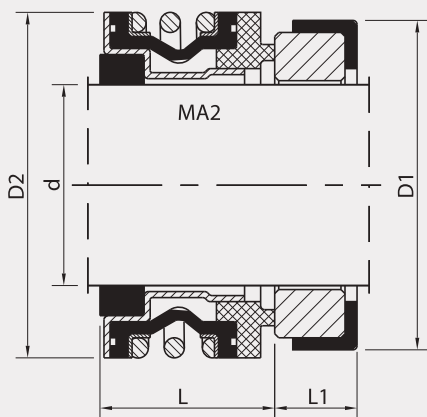
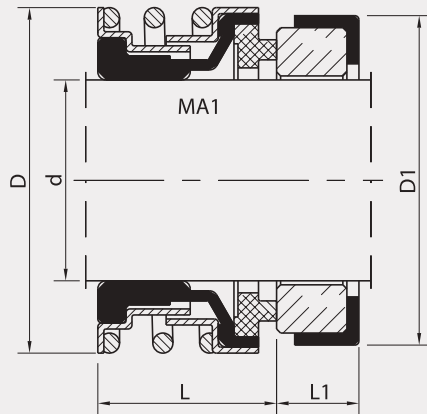

| | MA1 | | MA2 | | BR2 | | BR7 | |
|--|-------|-------|-------|------|-------|------|-------|------|
| | d | D | D2 | L | D1 | L1 | D1 | L1 |
| | .500 | .917 | 1.062 | .656 | 1.000 | .312 | - | - |
| | .625a | 1.185 | 1.218 | .718 | 1.250 | .406 | 1.187 | .343 |
| | .750a | 1.302 | 1.343 | .718 | 1.375 | .406 | - | - |
| | 1.000 | 1.552 | 1.687 | .812 | 1.625 | .437 | - | - |

Technical features

- Single seal
- Unbalanced
- Bi-directional
- Elastomer bellows

Operating limits

P = 72 PSI (MA1) - 150 PSI (MA2)
 T = -95 to 320°F
 V = 32 ft/s

Available products:

- Miami 1 (MA1)
- Miami 2 (MA2)

Mating rings

- BR2 (standard)
- BR7*

| Description | Materials |
|-----------------|---|
| Primary rings | silicon carbide, carbon graphite, phenolic graphite, tungsten carbide |
| Mating rings | silicon carbide, ceramic, tungsten carbide |
| Secondary seals | NBR, EPDM, Viton |
| Metal parts | Stainless 304 / Stainless 316* |

*upon request

San Francisco

Compact elastomer bellows seals



Technical features

- Single seal
- Unbalanced
- Spring enclosed
- Bi-directional
- Elastomer bellows

Operating limits

P = 87 PSI

T = -95 to 320°F

V = 32 ft/s

| Description | Materials |
|-----------------|---|
| Primary rings | silicon carbide, tungsten carbide, carbon graphite, phenolic graphite |
| Mating rings | silicon carbide, ceramic, tungsten carbide |
| Secondary seals | NBR, EPDM, Viton |
| Metal parts | Stainless 304 / Stainless 316* |

*upon request

Mating rings

- BR6 (standard)
- FR5 (insert)
- FR4 (monolithic)

For more details on mating rings see page 29

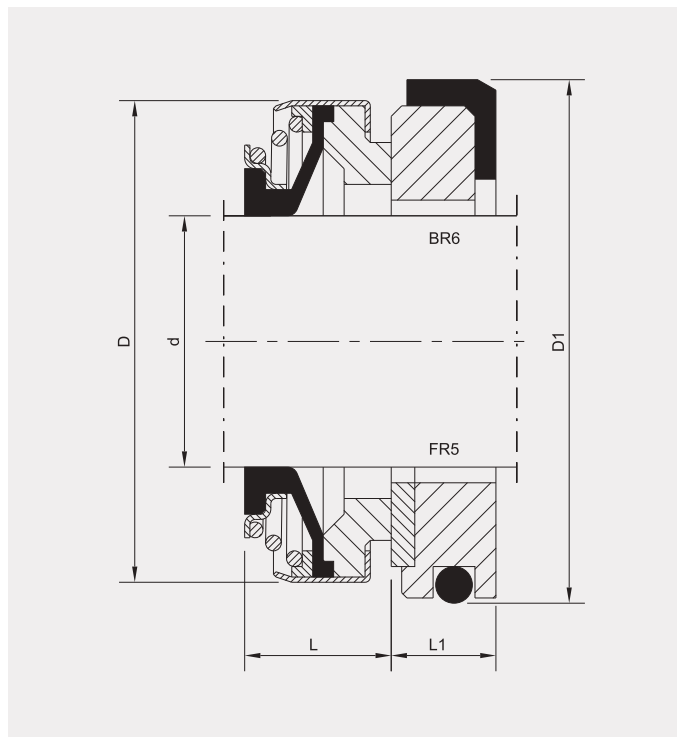

| d | SF | L | BR6-FR5 | |
|-----|-----|----|---------|------|
| | | | D1 | L1 |
| 8a | 20 | 11 | 26.0 | 4.0 |
| 8b | 20 | 11 | 22.0 | 4.0 |
| 8c | 24 | 11 | 26.0 | 8.0 |
| 9 | 24 | 11 | 26.0 | 8.0 |
| 10 | 24 | 11 | 26.0 | 8.0 |
| 11 | 24 | 11 | 26.0 | 8.0 |
| 12a | 24 | 13 | 26.0 | 5.5 |
| 12b | 24 | 13 | 26.0 | 8.0 |
| 12c | 32 | 13 | 35.0 | 8.0 |
| 13 | 24 | 13 | 26.0 | 8.0 |
| 14a | 28 | 13 | 25.0 | 7.0 |
| 14b | 28 | 13 | 28.5 | 8.0 |
| 14c | 32 | 13 | 29.5 | 8.0 |
| 14d | 32 | 13 | 35.0 | 8.0 |
| 14e | 32 | 13 | 30.0 | 8.0 |
| 15a | 32 | 13 | 29.5 | 8.0 |
| 15b | 32 | 13 | 38.0 | 8.0 |
| 15c | 35 | 13 | 38.0 | 8.0 |
| 16a | 32 | 13 | 29.5 | 8.0 |
| 16b | 35 | 13 | 38.0 | 8.0 |
| 16c | 39 | 13 | 38.0 | 8.0 |
| 16d | 39 | 13 | 42.0 | 8.0 |
| 17 | 39 | 13 | 42.0 | 8.0 |
| 18 | 39 | 13 | 42.0 | 8.0 |
| 19 | 39 | 13 | 42.0 | 8.0 |
| 20a | 39 | 13 | 42.0 | 8.0 |
| 20b | 42 | 13 | 45.0 | 10.0 |
| 22 | 42 | 13 | 45.0 | 10.0 |
| 23 | 47 | 14 | 50.0 | 10.0 |
| 24 | 47 | 14 | 50.0 | 10.0 |
| 25a | 42 | 14 | 50.0 | 10.0 |
| 25b | 47 | 14 | 50.0 | 10.0 |
| 26 | 47 | 14 | 50.0 | 10.0 |
| 28 | 54 | 15 | 57.0 | 10.0 |
| 30 | 54 | 15 | 57.0 | 10.0 |
| 32 | 54 | 15 | 57.0 | 10.0 |
| 35 | 60 | 16 | 63.0 | 10.0 |
| 38 | 65 | 18 | 68.0 | 12.0 |
| 40 | 65 | 18 | 68.0 | 12.0 |
| 45 | 70 | 20 | 73.0 | 12.0 |
| 50 | 85 | 23 | 88.0 | 15.0 |
| 55 | 85 | 23 | 88.0 | 15.0 |
| 60 | 105 | 30 | 110.0 | 15.0 |
| 65 | 105 | 30 | 110.0 | 15.0 |
| 70 | 105 | 32 | 110.0 | 15.0 |

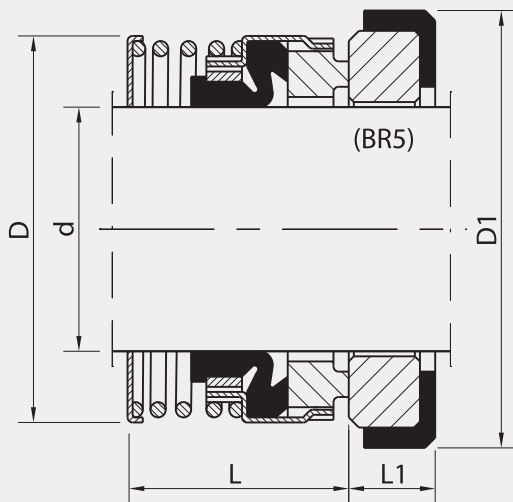

| d | *LO | | BR5 | |
|----|------|----|-----|----|
| | D | L | D1 | L1 |
| 10 | 20.6 | 16 | 24 | 7 |
| 11 | 21.8 | 16 | 24 | 7 |
| 12 | 21.8 | 17 | 26 | 7 |
| 13 | 26.4 | 17 | 26 | 7 |
| 14 | 26.4 | 18 | 28 | 7 |
| 15 | 26.4 | 18 | 28 | 7 |
| 16 | 29.5 | 19 | 32 | 8 |
| 17 | 29.5 | 19 | 32 | 8 |
| 18 | 29.5 | 18 | 35 | 8 |
| 19 | 29.5 | 18 | 35 | 8 |
| 20 | 31.6 | 20 | 38 | 8 |
| 22 | 33.6 | 20 | 40 | 8 |
| 25 | 39.6 | 20 | 44 | 9 |
| 28 | 45.0 | 21 | 46 | 9 |
| 30 | 46.6 | 22 | 50 | 9 |
| 32 | 46.6 | 24 | 54 | 9 |
| 35 | 50.8 | 26 | 58 | 10 |
| 38 | 54.3 | 27 | 60 | 10 |
| 40 | 57.3 | 28 | 64 | 10 |
| 45 | 61.3 | 30 | 66 | 10 |
| 50 | 67.8 | 32 | 72 | 10 |

Technical features

- Single seal
- Unbalanced
- Single spring
- Bi-directional
- Elastomer bellows
- With captive primary ring

Operating limits

P = 72 PSI
T = -95 to 320°F
V = 52 ft/s

| Description | Materials |
|-----------------|--|
| Primary rings | silicon carbide, tungsten carbide, carbon graphite |
| Mating rings | silicon carbide, tungsten carbide, ceramic |
| Secondary seals | NBR, EPDM, Viton |
| Metal parts | Stainless 304 / Stainless 316* |

*upon request

Mating rings

- BR 5

Melbourne

Elastomer bellows seals

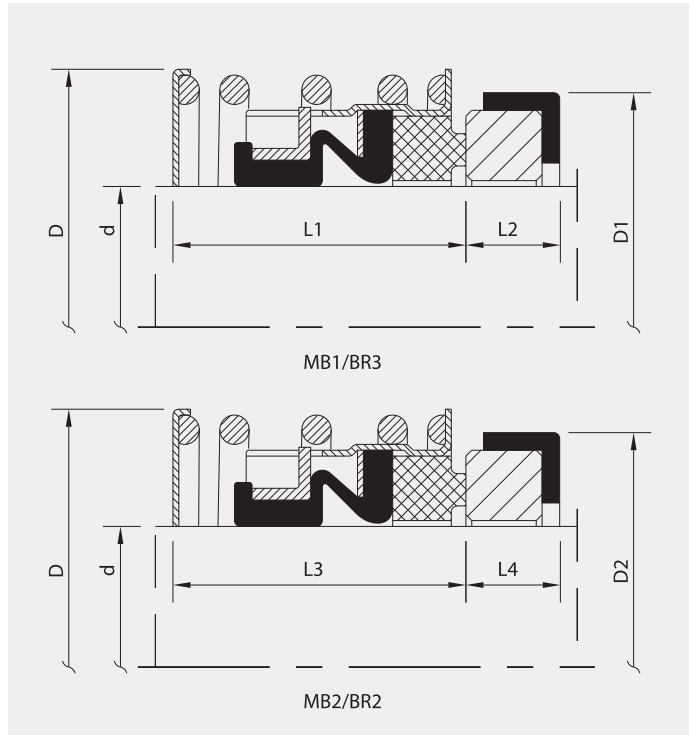

Technical features

- Single spring
- Unbalanced
- Bi-directional
- Elastomer bellows

Operating limits

P = 290 PSI
 T = -95 to 320°F
 V = 65 ft/s

| Description | Materials |
|-----------------|--|
| Primary rings | silicon carbide, tungsten carbide, carbon graphite |
| Mating rings | silicon carbide, tungsten carbide, ceramic |
| Secondary seals | NBR, EPDM, Viton |
| Metal parts | Stainless 304 / Stainless 316* |

* upon request

Available products:

- Melbourne 1 (MB1)
- Melbourne 2 (MB2)

Mating rings

- For MB1: BR3 (standard)
- For MB2: BR2 (standard), FR1

| d (inc) | d (mm) | D | MB1 L1 | MB2 L3 | BR3 D1 L2 | BR2 D2 L4 |
|---------|--------|-------|-----------|-----------|--------------|--------------|
| .500 | 12 | 1.187 | 1.000 | .813 | 1.094 .344 | 1.000 .312 |
| .625 | 14-16 | 1.312 | 1.000 | .875 | 1.219 .406 | 1.250 .406 |
| .750 | 18 | 1.437 | 1.000 | .875 | 1.344 .406 | 1.375 .406 |
| .875 | 20-22 | 1.562 | 1.000 | .937 | 1.469 .406 | 1.500 .406 |
| 1.000 | 24-25 | 1.791 | 1.000 | 1.000 | 1.594 .406 | 1.625 .437 |
| 1.125 | 28 | 1.910 | 1.312 | 1.062 | 1.875 .472 | 1.750 .437 |
| 1.250 | 30-32 | 2.061 | 1.312 | 1.062 | 2.000 .472 | 1.875 .437 |
| 1.375 | 33-35 | 2.250 | 1.312 | 1.125 | 2.125 .472 | 2.000 .437 |
| 1.500 | 38 | 2.375 | 1.312 | 1.125 | 2.250 .472 | 2.125 .437 |
| 1.625 | 40 | 2.718 | 1.312 | 1.375 | 2.375 .472 | 2.375 .500 |
| 1.750 | 43-45 | 2.750 | 1.594 | 1.375 | 2.500 .472 | 2.500 .500 |
| 1.875 | 48 | 2.875 | 1.594 | 1.500 | 2.625 .472 | 2.625 .500 |
| 2.000 | 50 | 3.000 | 1.594 | 1.500 | 2.750 .531 | 2.750 .500 |
| 2.125 | 53 | 3.250 | 1.615 | 1.687 | 2.875 .531 | 3.000 .562 |
| 2.250 | 55 | 3.375 | 1.615 | 1.687 | 3.000 .531 | 3.125 .562 |
| 2.375 | 60 | 3.500 | 1.615 | 1.812 | 3.125 .531 | 3.250 .562 |
| 2.500 | 63 | 3.625 | 1.615 | 1.812 | 3.250 .531 | 3.375 .562 |
| 2.625 | 65 | 3.875 | 1.929 | 1.937 | 3.625 .625 | 3.375 .625 |
| 2.750 | 70 | 4.000 | 1.929 | 1.937 | 3.750 .625 | 3.500 .625 |
| 2.875 | 73 | 4.125 | 2.047 | 2.062 | 3.875 .625 | 3.750 .625 |
| 3.000 | 75 | 4.250 | 2.047 | 2.062 | 4.000 .625 | 3.875 .625 |
| 3.125 | 80 | 4.562 | 2.208 | 2.187 | 4.375 .781 | - - |
| 3.250 | - | 4.687 | 2.208 | 2.187 | 4.500 .781 | - - |
| 3.375 | 85 | 4.812 | 2.208 | 2.187 | 4.625 .781 | - - |
| 3.500 | - | 4.937 | 2.208 | 2.187 | 4.750 .781 | - - |
| 3.625 | 90 | 5.125 | 2.323 | 2.312 | 4.875 .781 | - - |
| 3.750 | 95 | 5.250 | 2.323 | 2.312 | 5.000 .781 | - - |
| 3.875 | - | 5.437 | 2.441 | 2.312 | 5.125 .781 | - - |
| 4.000 | 100 | 5.562 | 2.441 | 2.312 | 5.250 .781 | - - |
| 4.500 | 110 | 5.315 | - | 2.312 | - - | - - |
| 4.750 | 120 | 5.709 | - | 2.835 | - - | - - |

Munich

Elastomer bellows seals

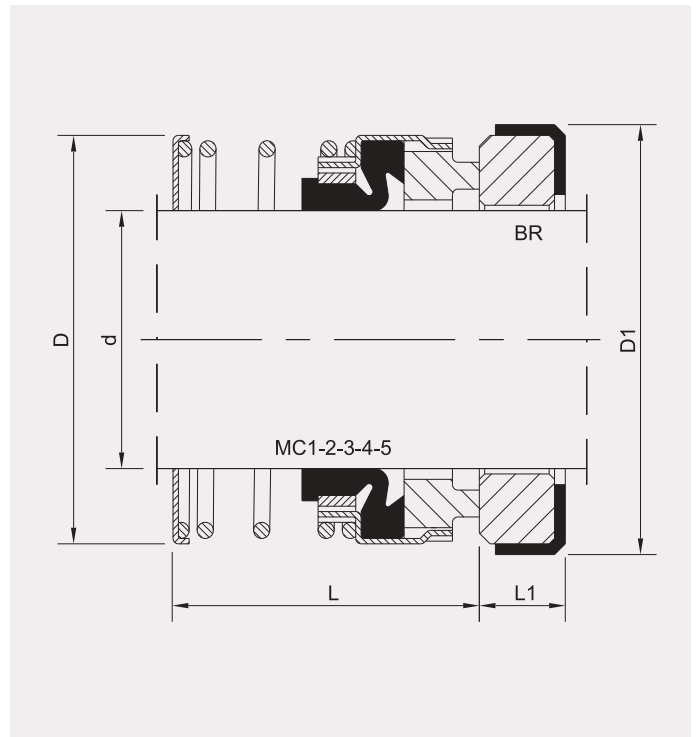

Technical features

- Unbalanced
- Single spring
- Bi-directional
- Elastomer bellows

Operating limits

P = 232 PSI
 T = -95 to 320°F
 V = 49 ft/s

| Description | Materials |
|-----------------|--|
| Primary rings | silicon carbide, tungsten carbide, carbon graphite |
| Mating rings | silicon carbide, tungsten carbide, ceramic |
| Secondary seals | NBR, EPDM, Viton |
| Metal parts | Stainless 304 / Stainless 316* |

* upon request

Available products:

- | Imperial size | Metric size |
|------------------|------------------|
| • Munich 1 (MC1) | • Munich 4 (MC4) |
| • Munich 2 (MC2) | • Munich 5 (MC5) |
| • Munich 3 (MC3) | |

Mating rings

- For MC1: BR3 (standard)
 - For MC2, MC3: BR2 (standard), FR1
 - For MC5: BR1 (standard), AU2*, AU3*
- For more details on mating rings see page 29

| d (inc) | MC1 | | BR2 - FR1 | | AU4* | MC2 | | MC3 | |
|---------|-------|-------|-----------|------|------|-------|-------|-------|-------|
| | D | L | D1 | L1 | L1 | D | L | D | L |
| .375 | .858 | 1.000 | .875 | .312 | .261 | .812 | .812 | .791 | .812 |
| .500 | .898 | 1.000 | 1.000 | .312 | .261 | .937 | .812 | .898 | .812 |
| .625 | 1.039 | 1.000 | 1.250 | .406 | .297 | 1.062 | .875 | 1.039 | .875 |
| .750 | 1.161 | 1.000 | 1.375 | .406 | .297 | 1.187 | .875 | 1.161 | .875 |
| .813 | 1.323 | 1.000 | 1.375 | .406 | .297 | 1.312 | .937 | 1.323 | .937 |
| .875 | 1.323 | 1.000 | 1.500 | .406 | .297 | 1.312 | .937 | 1.323 | .937 |
| 1.000 | 1.677 | 1.000 | 1.625 | .437 | .297 | 1.687 | 1.000 | 1.539 | 1.000 |
| 1.125 | 1.803 | 1.312 | 1.750 | .437 | .297 | 1.812 | 1.062 | 1.673 | 1.062 |
| 1.250 | 1.890 | 1.312 | 1.875 | .437 | .297 | 1.937 | 1.062 | 1.795 | 1.062 |
| 1.375 | 2.063 | 1.312 | 2.000 | .437 | .297 | 2.062 | 1.125 | 1.929 | 1.125 |
| 1.437 | 2.063 | 1.312 | 2.125 | .437 | .297 | 2.187 | 1.125 | 2.047 | 1.125 |
| 1.500 | 2.189 | 1.312 | 2.125 | .437 | .297 | 2.187 | 1.125 | 2.047 | 1.125 |
| 1.625 | 2.252 | 1.312 | 2.375 | .500 | .335 | 2.500 | 1.375 | 2.252 | 1.375 |
| 1.750 | 2.559 | 1.594 | 2.500 | .500 | .335 | 2.625 | 1.375 | 2.386 | 1.375 |
| 1.875 | 2.614 | 1.594 | 2.625 | .500 | .335 | 2.750 | 1.500 | 2.512 | 1.500 |
| 2.000 | 2.701 | 1.594 | 2.750 | .500 | .335 | 2.875 | 1.500 | 2.583 | 1.500 |
| 2.125 | 2.886 | 1.615 | 3.000 | .562 | .375 | 3.000 | 1.687 | 2.819 | 1.687 |
| 2.250 | 3.079 | 1.615 | 3.125 | .562 | .375 | 3.125 | 1.687 | 3.028 | 1.687 |
| 2.375 | 3.213 | 1.615 | 3.250 | .562 | .375 | 3.250 | 1.812 | 3.087 | 1.812 |
| 2.500 | 3.319 | 1.615 | 3.375 | .562 | .375 | 3.343 | 1.812 | 3.197 | 1.812 |
| 2.625 | 3.449 | 1.929 | 3.375 | .625 | .375 | 3.500 | 1.937 | 3.327 | 1.937 |
| 2.750 | 3.630 | 1.929 | 3.500 | .625 | .375 | 3.750 | 1.937 | 3.528 | 1.937 |
| 2.875 | 3.724 | 2.047 | 3.750 | .625 | .473 | 3.875 | 2.062 | 3.701 | 2.062 |
| 3.000 | 4.031 | 2.047 | 3.875 | .625 | .473 | 4.000 | 2.062 | 3.846 | 2.062 |

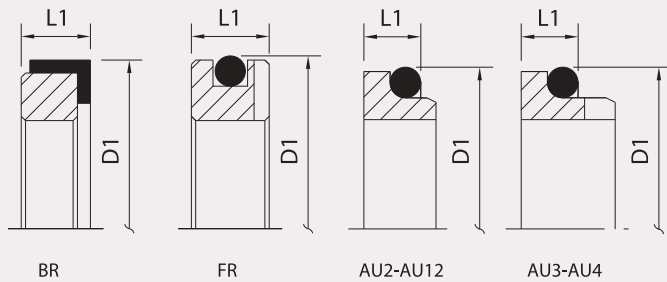

| d (mm) | *MC1 | | BR3 - AU12* | | d (mm) | MC5 | | MC4 | BR1 - AU2* - AU3* | |
|--------|-------|------|-------------|------|--------|-------|------|------|-------------------|------|
| | D | L | D1 | L1 | | D | L | L | D1 | L1 |
| 10 | 21.8 | 25.4 | 24.6 | 8.7 | 10 | 20.1 | 23.9 | 16.0 | 21.0 | 8.6 |
| 12 | 22.8 | 25.4 | 27.8 | 8.7 | 12 | 22.8 | 23.9 | 16.5 | 23.0 | 8.6 |
| 14-16 | 26.4 | 25.4 | 31.0 | 10.3 | 14 | 22.8 | 26.4 | 16.5 | 25.0 | 8.6 |
| 18-19 | 29.5 | 25.4 | 34.2 | 10.3 | 16 | 26.4 | 26.4 | 17.6 | 27.0 | 8.6 |
| 20 | 33.6 | 25.4 | 35.7 | 10.3 | 18 | 29.5 | 27.5 | 19.6 | 33.0 | 10.0 |
| 22 | 33.6 | 25.4 | 37.3 | 10.3 | 19 | 29.5 | 27.5 | - | 35.0 | 10.0 |
| 24-25 | 42.6 | 25.4 | 40.5 | 10.3 | 20 | 33.6 | 27.5 | 20.6 | 35.0 | 10.0 |
| 28 | 45.8 | 33.3 | 47.6 | 12.0 | 22 | 33.6 | 27.5 | 22.1 | 37.0 | 10.0 |
| 30-32 | 48.0 | 33.3 | 50.8 | 12.0 | 24 | 38.0 | 30.0 | 23.6 | 39.0 | 10.0 |
| 33 | 52.4 | 33.3 | 53.9 | 12.0 | 25 | 39.1 | 30.0 | 25.1 | 40.0 | 10.0 |
| 35 | 52.4 | 33.3 | 53.9 | 12.0 | 28 | 42.5 | 32.5 | 26.6 | 43.0 | 10.0 |
| 38 | 55.6 | 33.3 | 57.2 | 12.0 | 30 | 44.0 | 32.5 | 26.6 | 45.0 | 10.0 |
| 40 | 57.2 | 33.3 | 60.3 | 12.0 | 32 | 45.6 | 32.5 | 30.1 | 48.0 | 10.0 |
| 42-45 | 65.0 | 40.5 | 63.5 | 12.0 | 33 | 45.6 | 32.5 | 30.1 | 48.0 | 10.0 |
| 48 | 66.4 | 40.5 | 66.7 | 12.0 | 35 | 49.0 | 34.0 | 30.4 | 50.0 | 10.0 |
| 50 | 68.6 | 40.5 | 69.8 | 13.5 | 38 | 52.0 | 34.0 | 33.6 | 56.0 | 11.0 |
| 53 | 73.3 | 41.0 | 73.0 | 13.5 | 40 | 55.8 | 34.0 | 36.6 | 58.0 | 11.0 |
| 55 | 78.2 | 41.0 | 76.2 | 13.5 | 42 | 60.6 | 34.0 | - | 61.0 | 11.0 |
| 58-60 | 81.6 | 41.0 | 79.4 | 13.5 | 43 | 60.6 | 34.0 | - | 61.0 | 11.0 |
| 63 | 84.3 | 41.0 | 82.5 | 13.5 | 45 | 60.6 | 34.0 | 41.4 | 63.0 | 11.0 |
| 65 | 87.6 | 49.0 | 92.1 | 15.9 | 48 | 63.8 | 34.0 | 46.9 | 66.0 | 11.0 |
| 70 | 92.2 | 49.0 | 95.2 | 15.9 | 50 | 65.6 | 34.5 | 47.9 | 70.0 | 13.0 |
| 73 | 94.6 | 52.0 | 98.4 | 15.9 | 53 | 71.6 | 34.5 | 52.8 | 73.0 | 13.0 |
| 75 | 102.4 | 52.0 | 101.6 | 15.9 | 55 | 71.6 | 34.5 | 55.8 | 75.0 | 13.0 |
| - | 104.0 | 56.1 | 111.1 | 19.8 | 58 | 78.4 | 39.5 | - | 78.0 | 13.0 |
| 80 | 104.0 | 56.1 | 114.3 | 19.8 | 60 | 78.4 | 39.5 | 56.8 | 80.0 | 13.0 |
| 85 | 108.0 | 56.1 | 117.5 | 19.8 | 63 | 81.2 | 39.5 | - | 83.0 | 13.0 |
| | | | | | 65 | 84.5 | 39.5 | 57.8 | 85.0 | 13.0 |
| | | | | | 68 | 89.6 | 37.2 | 59.5 | 90.0 | 15.3 |
| | | | | | 70 | 89.6 | 44.7 | 59.8 | 92.0 | 15.3 |
| | | | | | 75 | 96.6 | 44.7 | 60.8 | 97.0 | 15.3 |
| | | | | | 80 | 104.0 | 44.3 | - | 105.0 | 15.7 |
| | | | | | 85 | 107.7 | 44.3 | - | 110.0 | 15.7 |
| | | | | | 90 | 111.0 | 49.3 | - | 115.0 | 15.7 |
| | | | | | 95 | 119.0 | 49.3 | - | 120.0 | 15.7 |
| | | | | | 100 | 124.0 | 49.3 | - | 125.0 | 15.7 |

Sydney

Elastomer bellows seals

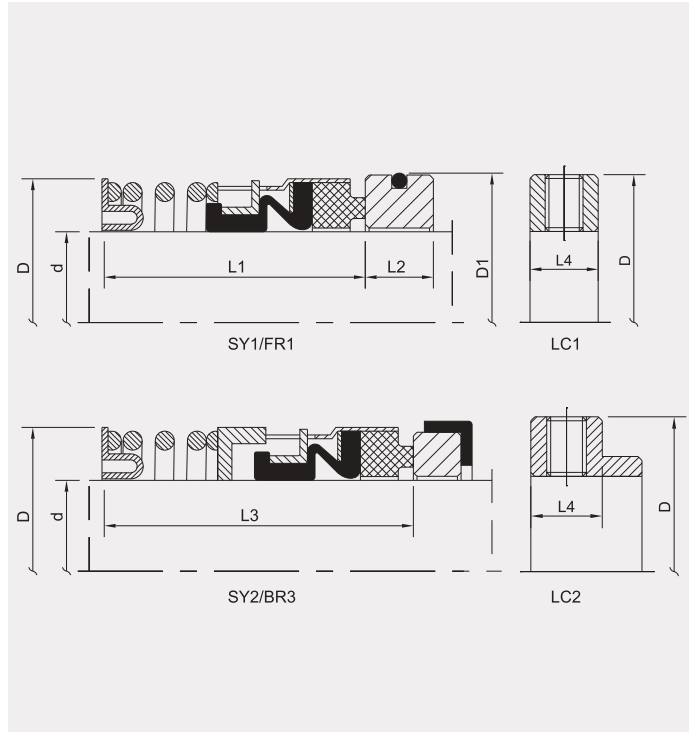

Technical features

- Single spring
- Unbalanced
- Bi-directional
- Elastomer bellows

Operating limits

P = 290 PSI
 T = -95 to 320 °F
 V = 65 ft/s

| Description | Materials |
|-----------------|--|
| Primary rings | silicon carbide, carbon graphite, tungsten carbide |
| Mating rings | silicon carbide, ceramic, tungsten carbide |
| Secondary seals | NBR, EPDM, Viton |
| Metal parts | Stainless 304 / Stainless 316* |

* upon request

Available products:

- Sydney 1 (SY1)
- Sydney 2 (SY2)

Mating rings

- For SY1: FR1 (standard), BR2
 - For SY2: BR3 (standard), BR1, BR2
 - LC1 - LC2: Lock Collar (Stainless 304 / Stainless 316*)
- For more details on mating rings see page 29

| d (inc) | d (mm) | D | SY1 L1 | SY2 L3 | FR1 D1 | L2 | LC1 - LC2 L4 |
|---------|--------|-------|-----------|-----------|-----------|------|-----------------|
| .625 | 14-16 | 1.093 | 1.312 | 1.719 | 1.250 | .406 | .312 |
| .750 | 18 | 1.218 | 1.312 | 1.719 | 1.375 | .406 | .312 |
| .875 | 20-22 | 1.343 | 1.375 | 1.719 | 1.500 | .406 | .312 |
| 1.000 | 24-25 | 1.500 | 1.562 | 1.719 | 1.625 | .437 | .375 |
| 1.125 | 28 | 1.625 | 1.625 | 2.375 | 1.750 | .437 | .375 |
| 1.250 | 30-32 | 1.812 | 1.625 | 2.375 | 1.875 | .437 | .375 |
| 1.375 | 33-35 | 1.875 | 1.687 | 2.375 | 2.000 | .437 | .375 |
| 1.500 | 38 | 2.000 | 1.687 | 2.375 | 2.125 | .437 | .375 |
| 1.625 | 40 | 2.250 | 2.000 | 2.375 | 2.375 | .500 | .375 |
| 1.750 | 43-45 | 2.375 | 2.000 | 2.781 | 2.500 | .500 | .375 |
| 1.875 | 48 | 2.500 | 2.125 | 2.781 | 2.625 | .500 | .375 |
| 2.000 | 50 | 2.625 | 2.125 | 2.781 | 2.750 | .500 | .375 |
| 2.125 | 53 | 2.812 | 2.375 | 2.795 | 3.000 | .562 | .375 |
| 2.250 | 55 | 2.937 | 2.375 | 2.795 | 3.125 | .562 | .500 |
| 2.375 | 60 | 3.062 | 2.500 | 2.795 | 3.250 | .562 | .500 |
| 2.500 | 63 | 3.187 | 2.500 | 2.795 | 3.375 | .562 | .500 |
| 2.625 | 65 | 3.375 | 2.750 | 2.750 | 3.375 | .625 | .500 |
| 2.750 | 70 | 3.500 | 2.750 | 2.750 | 3.500 | .625 | .500 |
| 2.875 | 73 | 3.625 | 2.875 | 2.875 | 3.750 | .625 | .500 |
| 3.000 | 75 | 3.750 | 2.875 | 2.875 | 3.875 | .625 | .500 |

Salvador

Conical spring o-ring mounted seals

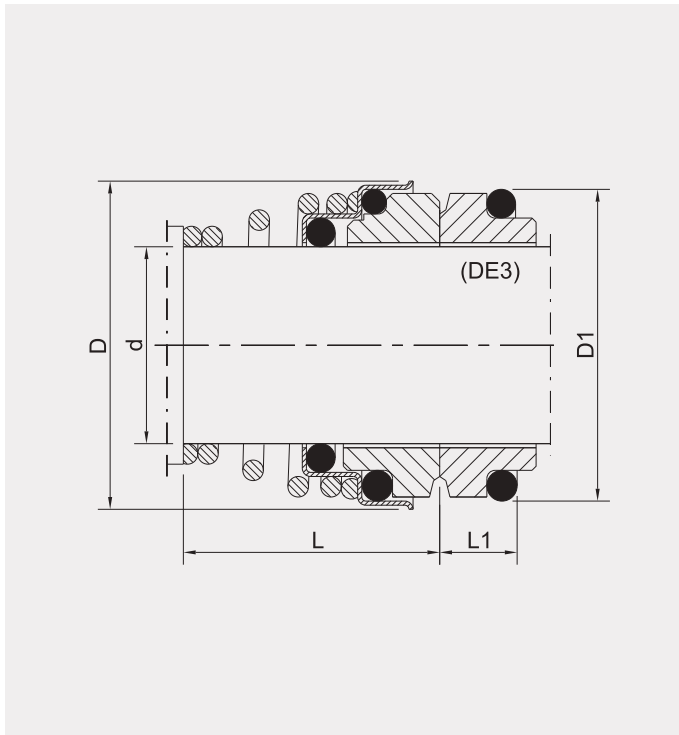

| d | SA1 | | DE3 | |
|----|-----|----|------|------|
| | D | L | D1 | L1 |
| 10 | 20 | 15 | 18.1 | 5.5 |
| 11 | 22 | 18 | 20.6 | 5.5 |
| 12 | 22 | 18 | 20.6 | 5.5 |
| 13 | 25 | 22 | 23.1 | 6.0 |
| 14 | 25 | 22 | 23.1 | 6.0 |
| 15 | 29 | 22 | 26.9 | 7.0 |
| 16 | 29 | 23 | 26.9 | 7.0 |
| 17 | 29 | 23 | 26.9 | 7.0 |
| 18 | 33 | 24 | 30.9 | 8.0 |
| 19 | 33 | 25 | 30.9 | 8.0 |
| 20 | 33 | 25 | 30.9 | 8.0 |
| 22 | 38 | 25 | 35.4 | 8.0 |
| 24 | 38 | 27 | 35.4 | 8.0 |
| 25 | 40 | 27 | 38.2 | 8.5 |
| 28 | 46 | 29 | 43.3 | 9.0 |
| 30 | 46 | 30 | 43.3 | 9.0 |
| 32 | 46 | 30 | 43.3 | 9.0 |
| 33 | 48 | 39 | 53.5 | 11.5 |
| 35 | 50 | 39 | 53.5 | 11.5 |
| 38 | 55 | 39 | 60.5 | 11.5 |
| 40 | 55 | 39 | 60.5 | 11.5 |

Technical features

- Single seal
- Unbalanced
- Conical spring
- Uni-directional

Operating limits

P = 145 PSI
 T = -95 to 320°F
 V = 65 ft/s

| Description | Materials |
|-----------------|---|
| Primary rings | silicon carbide, tungsten carbide, Aluminium oxide, stainless |
| Mating rings | silicon carbide, carbon graphite, tungsten carbide |
| Secondary seals | NBR, EPDM, Viton |
| Metal parts | Stainless 304 |

Mating rings

- DE3 (monolithic short seat)
- DE2 (monolithic long seat, anti-rotation pin slot)
- DE1 (face shrink fitted, anti-rotation pin slot)
- NL2 (monolithic short seat, anti-rotation pin slot, to DIN24960)
- NL1 (monolithic long seat, anti-rotation pin slot, to DIN24960)
- NL3 (face shrink fitted, anti-rotation pin slot, to DIN24960)

For more details on mating rings see page 29

Istanbul

Multiple springs o-ring/wedge seals



Technical features

- Single seal
- Balanced/Unbalanced
- Multiple springs
- Bi-directional

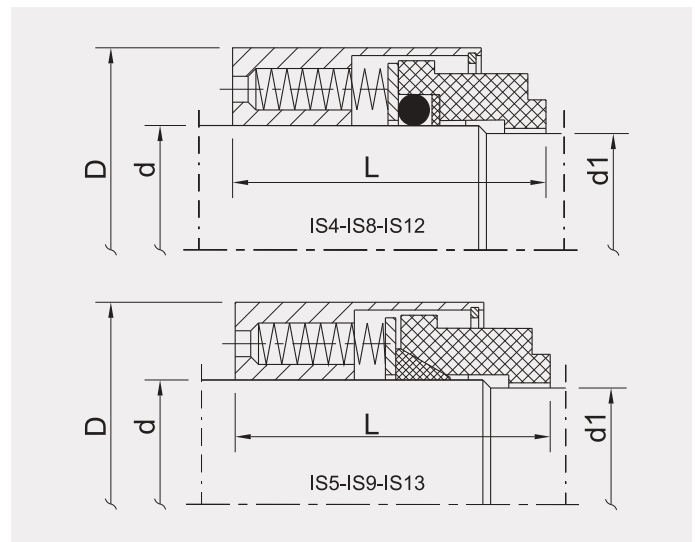
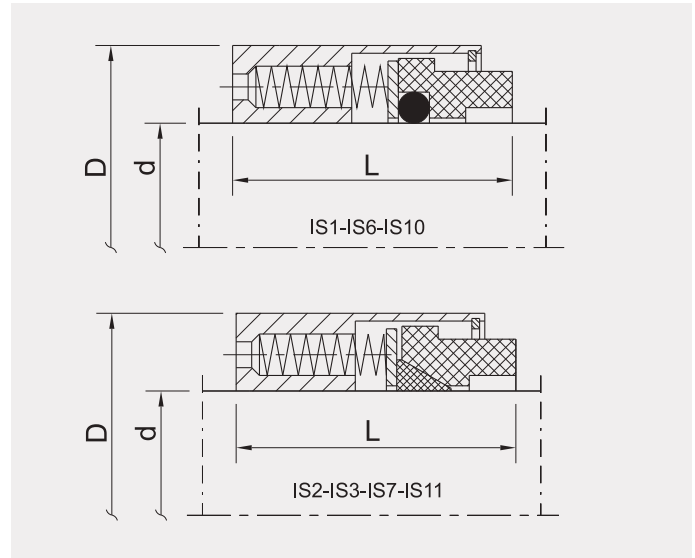

Operating limits

P = 348 to 580 PSI
T = -95 to 320°F
V = 82 ft/s

| Description | Materials |
|-----------------|--|
| Primary rings | silicon carbide, tungsten carbide, carbon graphite |
| Mating rings | silicon carbide, tungsten carbide, ceramic |
| Secondary seals | NBR, EPDM, PTFE, Viton |
| Metal parts | Stainless 304 / Stainless 316*, Hastelloy |

* upon request

Available products:

| Metric size | Imperial size | Imperial size |
|--------------------|----------------------|----------------------|
| • Istanbul 1 (IS1) | • Istanbul 6 (IS6) | • Istanbul 11 (IS11) |
| • Istanbul 2 (IS2) | • Istanbul 7 (IS7) | • Istanbul 12 (IS12) |
| • Istanbul 3 (IS3) | • Istanbul 8 (IS8) | • Istanbul 13 (IS13) |
| • Istanbul 4 (IS4) | • Istanbul 9 (IS9) | |
| • Istanbul 5 (IS5) | • Istanbul 10 (IS10) | |

Mating rings

- For IS1: ES1, ES3 (O-ring), ES2 (O-ring standard)
 - For IS2, IS3: ES3 (PTFE), ES2 (PTFE)
 - For IS6, IS8, IS10, IS12: ES4*, ES5*, FR1 (standard), FR2, FR3
 - For IS7, IS9, IS11, IS13: AU1*, AU5*, TR1*, TR2*, TR3*, TR4*
- For more details on mating rings see page 29

| IS1 - IS2 | | | IS3 | | IS4 - IS5 | | | | IS8 - IS9 | | | | IS12 - IS13 | | IS6 - IS7 | | | IS10 - IS11 | |
|-----------|-----|------|-------|----|-----------|-----|-----|------|-----------|-------|-------|-------|-------------|-------|-----------|-------|-------|-------------|-------|
| d | D | L | D | L | d | d1 | D | L | d | d1 | D | L | D | L | d | D | L | D | L |
| 14 | 24 | 23.0 | 28.4 | 21 | 18 | 14 | 32 | 30.5 | - | - | - | - | - | - | .500 | 1.031 | .812 | .937 | .937 |
| 16 | 26 | 23.0 | 30.8 | 19 | 20 | 16 | 34 | 30.5 | .625 | .500 | 1.187 | 1.062 | - | - | .625 | 1.187 | .750 | 1.062 | .937 |
| 18 | 32 | 24.0 | 33.8 | 22 | 22 | 18 | 36 | 31.5 | .75 | .625 | 1.312 | 1.181 | - | - | .750 | 1.312 | .875 | 1.187 | .937 |
| 20 | 34 | 24.0 | 34.8 | 24 | 24 | 20 | 38 | 31.5 | .875 | .750 | 1.437 | 1.260 | - | - | .875 | 1.437 | .937 | 1.312 | .937 |
| 22 | 36 | 24.0 | 35.6 | 24 | 26 | 22 | 40 | 31.5 | 1.000 | .875 | 1.562 | 1.312 | 1.437 | 1.312 | 1.000 | 1.562 | 1.000 | 1.437 | 1.000 |
| 24 | 38 | 26.7 | 38.8 | 25 | 28 | 24 | 42 | 34.2 | 1.125 | 1.000 | 1.687 | 1.375 | 1.562 | 1.375 | 1.125 | 1.687 | 1.062 | 1.562 | 1.000 |
| 25 | 39 | 27.0 | 39.8 | 25 | 30 | 25 | 44 | 34.5 | 1.250 | 1.125 | 1.875 | 1.375 | 1.687 | 1.375 | 1.250 | 1.875 | 1.062 | 1.687 | 1.000 |
| 28 | 42 | 30.0 | 43.4 | 27 | 33 | 28 | 47 | 37.5 | 1.375 | 1.125 | 2.000 | 1.437 | 1.937 | 1.687 | 1.375 | 2.000 | 1.125 | 1.937 | 1.375 |
| 30 | 44 | 30.5 | 46.4 | 27 | 35 | 30 | 49 | 38.0 | 1.500 | 1.250 | 2.125 | 1.437 | 1.937 | 1.437 | 1.500 | 2.125 | 1.125 | 1.937 | 1.125 |
| 32 | 46 | 30.5 | 49.7 | 29 | 38 | 33 | 54 | 38.0 | 1.625 | 1.375 | 2.375 | 1.750 | 2.250 | 1.593 | 1.625 | 2.375 | 1.375 | 2.250 | 1.156 |
| 33 | 47 | 30.5 | - | - | 40 | 35 | 56 | 38.0 | 1.750 | 1.500 | 2.500 | 1.750 | 2.312 | 1.750 | 1.750 | 2.500 | 1.375 | 2.312 | 1.375 |
| 35 | 49 | 30.5 | 51.3 | 29 | 43 | 38 | 59 | 39.5 | 1.875 | 1.625 | 2.625 | 1.750 | 2.500 | 1.750 | 1.875 | 2.625 | 1.375 | 2.500 | 1.375 |
| 38 | 54 | 32.0 | 54.5 | 29 | 45 | 40 | 61 | 39.5 | 2.000 | 1.750 | 2.750 | 1.750 | 2.625 | 1.750 | 2.000 | 2.750 | 1.375 | 2.625 | 1.375 |
| 40 | 56 | 32.0 | 59.6 | 35 | 48 | 43 | 64 | 39.5 | 2.125 | 1.875 | 3.000 | 2.062 | 2.812 | 2.062 | 2.125 | 3.000 | 1.687 | 2.812 | 1.687 |
| 43 | 59 | 32.0 | 64.0 | 35 | 50 | 45 | 66 | 39.5 | 2.250 | 2.000 | 3.125 | 2.062 | 2.843 | 1.750 | 2.250 | 3.125 | 1.687 | 2.843 | 1.375 |
| 45 | 61 | 32.0 | 64.7 | 35 | 53 | 48 | 69 | 39.5 | 2.375 | 2.125 | 3.250 | 2.062 | 3.000 | 2.062 | 2.375 | 3.250 | 1.687 | 3.000 | 1.687 |
| 48 | 64 | 32.0 | 67.2 | 35 | 55 | 50 | 71 | 44.0 | 2.500 | 2.250 | 3.375 | 2.062 | 3.125 | 1.750 | 2.500 | 3.375 | 1.687 | 3.125 | 1.375 |
| 50 | 66 | 34.0 | 69.6 | 35 | 58 | 53 | 78 | 44.0 | 2.625 | 2.375 | 3.500 | 2.062 | 3.250 | 2.062 | 2.625 | 3.500 | 1.687 | 3.250 | 1.687 |
| 53 | 69 | 34.0 | - | - | 60 | 55 | 80 | 44.0 | 2.750 | 2.500 | 3.625 | 2.062 | 3.375 | 2.062 | 2.750 | 3.625 | 1.687 | 3.375 | 1.687 |
| 55 | 71 | 34.0 | 77.7 | 43 | 63 | 58 | 83 | 49.0 | 2.875 | 2.625 | 3.750 | 2.062 | 3.500 | 2.062 | 2.875 | 3.750 | 1.687 | 3.500 | 1.687 |
| 58 | 78 | 39.0 | - | - | 65 | 60 | 85 | 49.0 | 3.000 | 2.750 | 3.812 | 2.062 | 3.625 | 2.062 | 3.000 | 3.812 | 1.687 | 3.625 | 1.687 |
| 60 | 80 | 39.0 | 82.7 | 43 | 68 | 63 | 88 | 49.0 | 3.125 | 2.875 | 3.937 | 2.062 | 3.750 | 2.062 | 3.125 | 3.937 | 1.687 | 3.750 | 1.687 |
| 63 | 83 | 39.0 | - | - | 70 | 65 | 90 | 49.0 | 3.250 | 3.000 | 4.125 | 2.062 | 3.875 | 2.062 | 3.250 | 4.125 | 1.687 | 3.875 | 1.687 |
| 65 | 85 | 39.0 | 87.7 | 43 | 75 | 70 | 95 | 55.5 | 3.375 | 3.125 | 4.250 | 2.062 | 4.000 | 2.062 | 3.375 | 4.250 | 1.687 | 4.000 | 1.687 |
| 68 | 88 | 39.0 | - | - | 80 | 75 | 104 | 55.5 | 3.500 | 3.250 | 4.375 | 2.062 | 4.125 | 2.062 | 3.500 | 4.375 | 1.687 | 4.125 | 1.687 |
| 70 | 90 | 45.5 | 92.6 | 43 | 85 | 80 | 109 | 55.0 | 3.625 | 3.375 | 4.500 | 2.062 | 4.250 | 2.062 | 3.625 | 4.500 | 1.687 | 4.250 | 1.687 |
| 75 | 95 | 45.5 | 96.3 | 43 | 90 | 85 | 114 | 60.0 | 3.750 | 3.500 | 4.625 | 2.062 | 4.375 | 2.062 | 3.750 | 4.625 | 1.687 | 4.375 | 1.687 |
| 80 | 104 | 45.0 | 101.1 | 43 | 95 | 90 | 119 | 60.0 | 3.875 | 3.625 | 4.750 | 2.062 | 4.500 | 2.062 | 3.875 | 4.750 | 1.687 | 4.500 | 1.687 |
| 85 | 109 | 45.0 | 107.7 | 43 | 100 | 95 | 124 | 60.0 | 4.000 | 3.750 | 4.875 | 2.062 | 4.625 | 2.062 | 4.000 | 4.875 | 1.687 | 4.625 | 1.687 |
| 90 | 114 | 50.0 | 112.7 | 43 | 105 | 100 | 129 | 60.0 | | | | | | | | | | | |
| 95 | 119 | 50.0 | 117.7 | 43 | | | | | | | | | | | | | | | |
| 100 | 124 | 50.0 | 122.7 | 43 | | | | | | | | | | | | | | | |

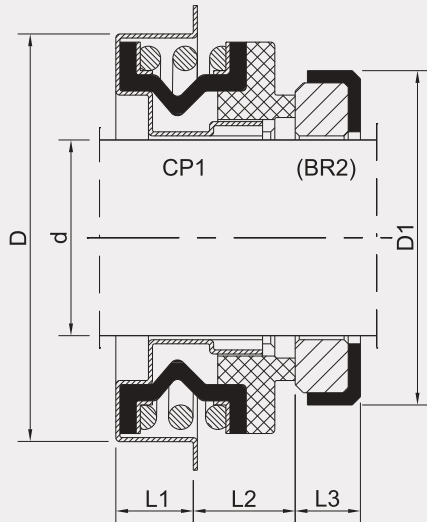

Technical features

- Single spring
- Unbalanced
- Bi-directional
- Elastomer bellows

Operating limits

P = 72 PSI
T = -95 to 320°F
V = 32 ft/s

| Description | Materials |
|-----------------|--|
| Primary rings | carbon graphite, silicon carbide, tungsten carbide |
| Mating rings | silicon carbide, tungsten carbide, ceramic |
| Secondary seals | NBR, EPDM |
| Metal parts | Stainless 304 / Stainless 316* |

* upon request

Mating rings

- BR2 (standard)

| d | D | CP | | BR2 | |
|-------|-------|-------|------|-------|------|
| | | L1 | L2 | D1 | L3 |
| .500 | 1.125 | 0.340 | .203 | 1.000 | .312 |
| .625 | 1.437 | 0.340 | .265 | 1.250 | .406 |
| .750 | 1.575 | 0.370 | .235 | 1.375 | .406 |
| 1.000 | 1.850 | 0.394 | .315 | 1.625 | .437 |

| d | D | CP | | D1 | L3 |
|----|------|------|------|------|-----|
| | | L1 | L2 | | |
| 20 | 40.0 | 9.5 | 12.0 | 35.0 | 5.0 |
| 30 | 52.0 | 10.0 | 12.0 | 48.0 | 8.0 |

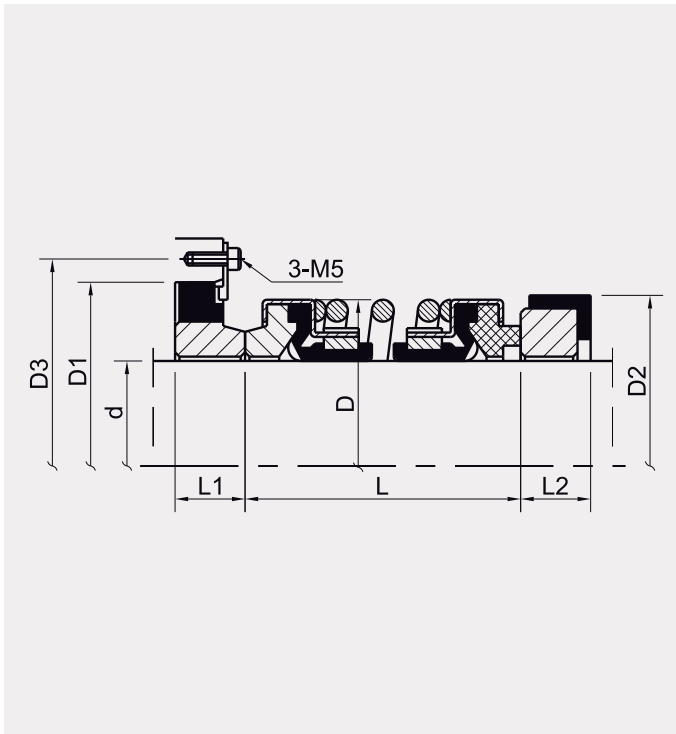

| d | *AT | | Type 1 | | Type 2 | | D3 |
|------|------|------|--------|------|--------|------|----|
| | D | L | D1 | L1 | D2 | L2 | |
| 15** | 27.0 | 26.0 | 30 | 5.0 | 30 | 5.0 | - |
| 16** | 27.0 | 26. | 0 | 5.0 | 30 | 5.0 | - |
| 20 | 34.0 | 32.5 | 44 | 8.5 | 38 | 8.0 | 60 |
| 25 | 39.5 | 34.5 | 50 | 8.0 | 44 | 9.0 | 60 |
| 30 | 48.0 | 40.2 | 57 | 9.8 | 50 | 9.0 | 70 |
| 35 | 51.5 | 41.0 | 65 | 10.5 | 58 | 9.5 | 80 |
| 40 | 57.0 | 42.5 | 70 | 12.0 | 64 | 10.0 | 85 |
| 45 | 62.9 | 43.0 | 70 | 12.0 | 66 | 10.0 | 90 |
| 50 | 68.0 | 45.4 | 80 | 13.0 | 72 | 11.1 | 95 |

Technical features

- Double seal
- Single spring
- Unbalanced
- Bi-directional
- Elastomer bellows

Operating limits

P = 72 PSI
T = -95 to 320°F
V = 52 ft/s



| Description | Materials |
|-----------------|--|
| Primary rings | silicon carbide, carbon graphite, tungsten carbide |
| Mating rings | silicon carbide, ceramic, tungsten carbide |
| Secondary seals | NBR, EPDM, Viton |
| Metal parts | Stainless 304 / Stainless 316* |

* upon request

** Retaining plate unavailable for 15 and 16 mm size

Hamburg

Hamburg 1

Operating Limits:
 Pressure: $\leq 1.0\text{MPa}$
 Speed: $\leq 10\text{m/s}$
 Temperature: $-30\text{C}^{\circ}+180\text{C}^{\circ}$

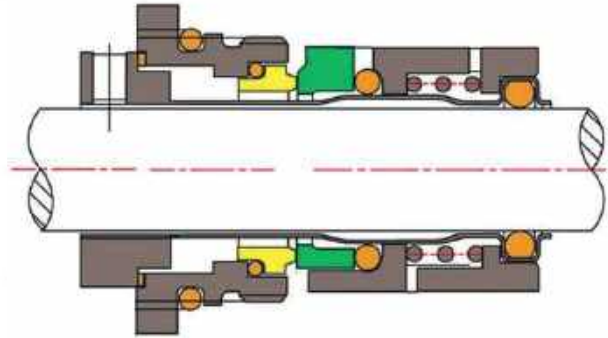

Hamburg 2

Operating Limits:
 Pressure: $\leq 1.0\text{MPa}$
 Speed: $\leq 10\text{m/s}$
 Temperature: $-30\text{C}^{\circ}+180\text{C}^{\circ}$

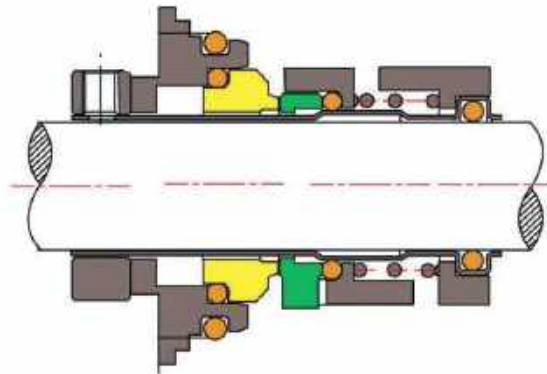

Hamburg 3

Operating Limits:
 Pressure: $\leq 1.2\text{MPa}$
 Speed: $\leq 10\text{m/s}$
 Temperature: $-30\text{C}^{\circ}+200\text{C}^{\circ}$

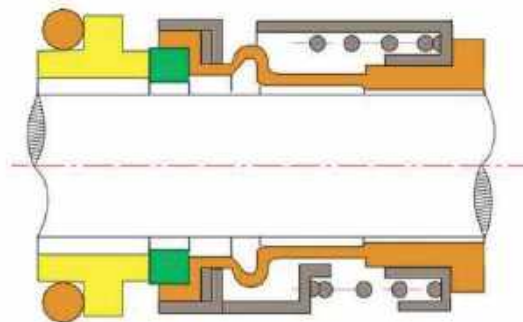

| Hamburg 1 | | | | |
|-----------|-------|---------------------------------|---------------|-------------|
| MATERIALS | SIZE | PUMP MOD. GRUNDFOS | CITYLINE COD. | DESCRIPTION |
| UUE | 12 mm | CR 1/3/5/8, CRN 1/3/5, CRN 1/3 | HA10001 | HA1012UUE |
| QQV | 12 mm | CR 1/3/5/8, CRN 1/3/5, CRN 1/3 | HA10002 | HA1012QQV |
| UUV | 12 mm | CR 1/3/5/8, CRN 1/3/5, CRN 1/3 | HA10003 | HA1012UUV |
| BUV | 12 mm | CR 1/3/5/8, CRN 1/3/5, CRN 1/3 | HA10004 | HA1012BUV |
| BUE | 16 mm | CR 10/15/20, CRN 10/15/20 | HA10005 | HA1016BUE |
| QQV | 16 mm | CR 10/15/20, CRN 10/15/20 | HA10006 | HA1016QQV |
| UUV | 16 mm | CR 10/15/20, CRN 10/15/20 | HA10007 | HA1016UUV |
| BUV | 16 mm | CR 10/15/20, CRN 10/15/21 | HA10008 | HA1016BUV |
| Hamburg 2 | | | | |
| BUE | 22 mm | CR 32/45/64/90, CRN 32/45/64/90 | HA20001 | HA2022BUE |
| UUE | 22 mm | CR 32/45/64/90, CRN 32/45/64/91 | HA20002 | HA2022UUE |
| QQV | 22 mm | CR 32/45/64/90, CRN 32/45/64/92 | HA20003 | HA2022QQV |
| UUV | 22 mm | CR 32/45/64/90, CRN 32/45/64/93 | HA20004 | HA2022UUV |
| Hamburg 3 | | | | |
| QQE | 12 mm | CR 2/4/8, CRN 2/4(S) | HA30001 | HA3012QQE |
| QQV | 12 mm | CR 2/4/8, CRN 2/4(S) | HA30002 | HA3012QQV |
| UUV | 12 mm | CR 2/4/8, CRN 2/4(S) | HA30003 | HA3012UUV |
| QQE | 16 mm | CR 8/16, CRN 8/16(S) | HA30004 | HA3016QQE |
| QQV | 16 mm | CR 8/16, CRN 8/16(S) | HA30005 | HA3016QQV |
| UUV | 16 mm | CR 8/16, CRN 8/16(S) | HA30006 | HA3016UUV |

Verona B

B, as in Bellow seal, referring to the bellow like secondary seal between the shaft and the rotating seal ring. The bellow seal is a reliable and sturdy construction that has served well in Flygt B pumps for many years. The single coil spring along with the bellow shaped secondary seal greatly reduces the risk of hampered spring motion and since there is always metal to metal contact with the oil housing, good heat dissipation is well provided for.

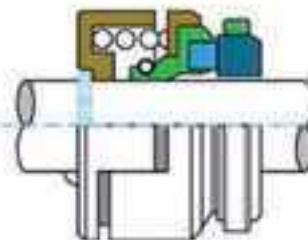

Verona I

I, as in Internal spring seal, referring to the protected position of the spring between the shaft and seal rings. This design concept first appeared in the 2201 but has gained popularity also in C pumps because of its high resistance to clogging.

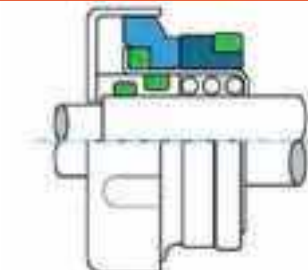

Verona O

O, as in Open coil spring seal, is used in smaller B pumps. This is a straightforward and durable design that can withstand a lot of abuse. The single coil spring, the flexible mounted O-ring and well dimensioned seal rings assure long life in all common applications.

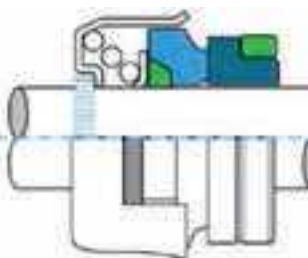

Verona P

P, as in Plug-in seal, has a number of features that make it easier to handle than conventional single seals. The seal comprises an inner and outer seal in one unit that is simply “plugged in” to the product without any special tools being required. The seal is designed for wear and clog resistance, and is suitable for all applications and the toughest media. The plug-n seal is standard in all new products.

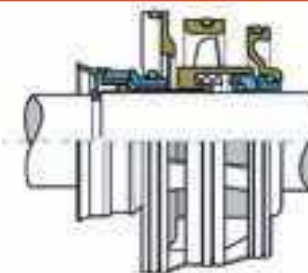

Verona S

S, as in Sleeve seal, referring to the sleeve shape of this stationary seal ring. The sleeve seal is a well proven design that is used in mixers and medium sized C pumps. Since the spring is placed in the oil housing and the exterior is flushed, the sleeve seal has excellent resistance to clogging and wear. There is also an inverted form of this seal, where the rotating ring is sleeve shaped, which is used in 2151 and 2084.

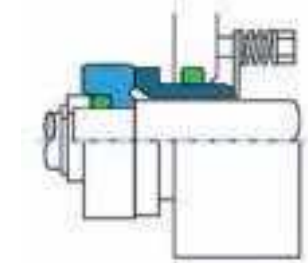

| DIAMETER (mm) | CITY LINE type | FLYGT type | Materials | Pump Model |
|---------------|----------------|-------------------------------|----------------|--|
| 20 | Verona B | TYPE B - BELLOW SEAL | UUV | 2024, 2066, 2075, 2101, 3065, 3080 |
| 20 | Verona B | TYPE B - BELLOW SEAL | QQV | 2024, 2066, 2075, 2101, 3065, 3080 |
| 22 | Verona B | TYPE B - BELLOW SEAL | UUV | 2070, 2102/040, 3082, 2040, 2071, 2102/041, 2102/210, 2102/220 |
| 22 | Verona B | TYPE B - BELLOW SEAL | QQV | 2070, 2102/040, 3082, 2040, 2071, 2102/041, 2102/210, 2102/220 |
| 25 | Verona B | TYPE B - BELLOW SEAL | UUV | |
| 25 | Verona B | TYPE B - BELLOW SEAL | QQV | |
| 28 | Verona B | TYPE B - BELLOW SEAL | UUV | 2082, 2090, 2125, 2140, 3101 |
| 28 | Verona B | TYPE B - BELLOW SEAL | QQV | 2082, 2090, 2125, 2140, 3101 |
| 30 | Verona B | TYPE B - BELLOW SEAL | UUV | |
| 30 | Verona B | TYPE B - BELLOW SEAL | QQV | |
| 35 | Verona B | TYPE B - BELLOW SEAL | UUV | |
| 35 | Verona B | TYPE B - BELLOW SEAL | QQV | |
| 35 | Verona I | TYPE I - INTERNAL SPRING SEAL | UUV | 2151/010, 3126/090, 3126/180, 2084, 2135, 2151/011, 2151/050, 3126/091, 3126/280, 3126/290 |
| 20 | Verona O | TYPE O - OPEN COIL SEAL | UUV | 2060, 3041/281, 3060, 3067/170, 3067/250, 3068, 3085/120, 3085/170, 3085/180, 3085/890 |
| 25 | Verona O | TYPE O - OPEN COIL SEAL | UUV | 3102 |
| 35 | Verona O | TYPE O - OPEN COIL SEAL | UUV | 3126/091, 3126/280, 3126/290, 3126/181, 3127, 4440, 5530 |
| 45 | Verona O | TYPE O - OPEN COIL SEAL | UUV | 2201, 3140, 3152, 4650, 4660 (SUPERIORE) |
| 45 | Verona S | TYPE S - SLEEVE SEAL | UUV | 2201, 3140, 3152, 4650, 4660 (INFERIORE) |
| 30 | Verona S | TYPE S - SLEEVE SEAL | UUV | |
| 35 | Verona S | TYPE S - SLEEVE SEAL | UUV | 2151/010, 3126/090, 3126/180 |
| 60 | Verona S | TYPE S - SLEEVE SEAL | UUV | 2250, 2290, 3200, 600, 3170, 3201, 4670, 4680, 7045 |
| 80 | Verona S | TYPE S - SLEEVE SEAL | UUV | 3230, 3305, 3357, 3231, 3306, 3356, 3300, 3355, 7050, 7051, 7060, 7076, 7055, 7061, 7080 |
| 20 | Verona P | TYPE P - PLUG-IN SEAL | UU/UUV/PLASTIC | 1520, 2610, 2620, 2630, 2640, 4610, 4620 |
| 25 | Verona P | TYPE P - PLUG-IN SEAL | UU/UUV/PLASTIC | 2660, 4630, 4640 |
| 35 | Verona P | TYPE P - PLUG-IN SEAL | UU/UUV/PLASTIC | 2670, 3153, 5100 (210, 211, 220, 221) |
| 45 | Verona P | TYPE P - PLUG-IN SEAL | UU/UUV/PLASTIC | 3171, 4650, 4660, 5100 (250, 251, 260, 261) |
| 60 | Verona P | TYPE P - PLUG-IN SEAL | UU/UUV/PLASTIC | 3202, 4670, 4680, 5100 (300, 310), 5150 (300, 310) |

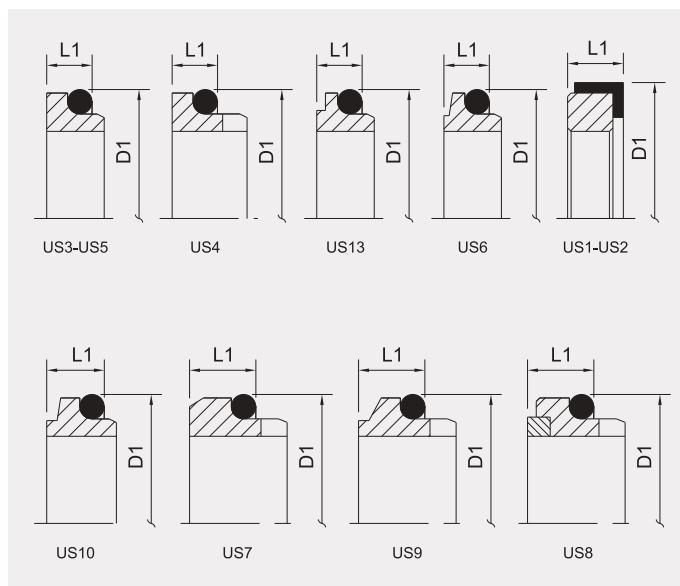

Technical features

- Mating rings for metric shaft sizes
- US3, US4, US5, US13, US7, US2, US1 available in: ceramic, stainless steel, silicon carbide, tungsten carbide.
- US6, US10, US9 available in: carbon graphite.

**upon request*

| d | US3 - US4* - US13* | | US5 - US1 - US6 | | US10 | | US7 - US9 - US8 | | US2 | | US12 | US11 | |
|-----|--------------------|------|-----------------|------|-------|------|-----------------|------|-------|------|-------|------|------|
| | D1 | L1 | D1 | L1 | D1 | L1 | D1 | L1 | D1 | L1 | D1 | L1 | L1 |
| 10 | 19.2 | 6.6 | 21.0 | 6.6 | 19.2 | 7.1 | 21.0 | 10.0 | 24.6 | 9.0 | - | - | - |
| 12 | 21.6 | 5.6 | 23.0 | 6.6 | 21.6 | 7.6 | 23.0 | 10.0 | 27.8 | 9.0 | - | - | - |
| 14 | 24.6 | 5.6 | 25.0 | 6.6 | 24.6 | 7.6 | 25.0 | 10.0 | 31.0 | 10.5 | - | - | - |
| 15 | 24.6 | 6.6 | 27.0 | 6.6 | 24.6 | 9.0 | 27.0 | 10.0 | 31.0 | 10.5 | - | - | - |
| 16 | 28.0 | 7.5 | 27.0 | 6.6 | 28.0 | 9.0 | 27.0 | 10.0 | 31.0 | 10.5 | - | - | - |
| 18 | 30.0 | 8.0 | 33.0 | 7.5 | 30.0 | 10.0 | 33.0 | 11.5 | 34.2 | 10.5 | 33.0 | 7.0 | 9.0 |
| 20 | 35.0 | 7.5 | 35.0 | 7.5 | 35.0 | 9.5 | 35.0 | 11.5 | 35.7 | 10.5 | 35.0 | 7.0 | 9.0 |
| 22 | 35.0 | 7.5 | 37.0 | 7.5 | 35.0 | 9.5 | 37.0 | 11.5 | 37.3 | 10.5 | 37.0 | 7.0 | 9.0 |
| 24 | 38.0 | 7.5 | 39.0 | 7.5 | 38.0 | 9.5 | 39.0 | 11.5 | 40.5 | 10.5 | 39.0 | 7.0 | 9.0 |
| 25 | 38.0 | 7.5 | 40.0 | 7.5 | 38.0 | 11.0 | 40.0 | 11.5 | 40.5 | 10.5 | 40.0 | 7.0 | 9.0 |
| 28 | 42.0 | 9.0 | 43.0 | 7.5 | 42.0 | 11.0 | 43.0 | 11.5 | 47.7 | 12.0 | 43.0 | 7.0 | 9.5 |
| 30 | 45.0 | 10.5 | 45.0 | 7.5 | 45.0 | 11.0 | 45.0 | 11.5 | 50.8 | 12.0 | 45.0 | 7.0 | 9.5 |
| 32 | 48.0 | 10.5 | 48.0 | 7.5 | 48.0 | 11.0 | 48.0 | 11.5 | 50.8 | 12.0 | 48.0 | 7.0 | 9.5 |
| 33 | 50.0 | 11.0 | 48.0 | 7.5 | 50.0 | 11.5 | 48.0 | 11.5 | 54.0 | 12.0 | 48.0 | 7.0 | 9.5 |
| 35 | 52.0 | 11.0 | 50.0 | 7.5 | 52.0 | 11.5 | 50.0 | 11.5 | 54.0 | 12.0 | 50.0 | 7.0 | 9.5 |
| 38 | 55.0 | 10.3 | 56.0 | 9.0 | 55.0 | 11.5 | 56.0 | 14.0 | 57.2 | 12.0 | 56.0 | 8.0 | 10.5 |
| 40 | 58.0 | 10.8 | 58.0 | 9.0 | 58.0 | 11.5 | 58.0 | 14.0 | 60.4 | 12.0 | 58.0 | 8.0 | 10.5 |
| 42 | 62.0 | 12.0 | 61.0 | 9.0 | 60.0 | 14.3 | 61.0 | 14.0 | 63.5 | 12.0 | - | - | - |
| 43 | 62.0 | 12.0 | 61.0 | 9.0 | 62.0 | 14.3 | 61.0 | 14.0 | 63.5 | 12.0 | 61.0 | 8.0 | 10.5 |
| 45 | 64.0 | 11.6 | 63.0 | 9.0 | 64.0 | 14.3 | 63.0 | 14.0 | 63.5 | 12.0 | 63.0 | 8.0 | 10.5 |
| 48 | 68.4 | 11.6 | 66.0 | 9.0 | 68.4 | 14.3 | 66.0 | 14.0 | 66.7 | 12.0 | 66.0 | 8.0 | 10.5 |
| 50 | 69.3 | 11.6 | 70.0 | 9.5 | 69.3 | 14.3 | 70.0 | 15.0 | 69.9 | 13.5 | 70.0 | 9.5 | 12.0 |
| 53 | 72.3 | 12.3 | 73.0 | 11.0 | 72.3 | 14.3 | 73.0 | 15.0 | 73.1 | 13.5 | 73.0 | 9.5 | 12.0 |
| 55 | 75.4 | 13.3 | 75.0 | 11.0 | 75.4 | 15.3 | 75.0 | 15.0 | 76.2 | 13.5 | 75.0 | 9.5 | 12.0 |
| 58 | 78.4 | 13.3 | 78.0 | 11.0 | 78.4 | 15.3 | 78.0 | 15.0 | 79.4 | 13.5 | 78.0 | 10.5 | 13.0 |
| 60 | 80.4 | 13.3 | 80.0 | 11.0 | 80.4 | 15.3 | 80.0 | 15.0 | 79.4 | 13.5 | 80.0 | 10.5 | 13.0 |
| 63 | 83.4 | 13.3 | 83.0 | 11.0 | 83.4 | 15.3 | 83.0 | 15.0 | 82.5 | 13.5 | 83.0 | 10.5 | 13.0 |
| 65 | 85.4 | 13.0 | 85.0 | 11.0 | 85.4 | 15.3 | 85.0 | 15.0 | 92.1 | 16.0 | 85.0 | 10.5 | 13.0 |
| 68 | 91.5 | 13.7 | 90.0 | 11.3 | 91.5 | 16.0 | 90.0 | 18.0 | 95.3 | 16.0 | 90.0 | 11.0 | 13.5 |
| 70 | 92.0 | 13.0 | 92.0 | 11.3 | 92.0 | 15.3 | 92.0 | 18.0 | 95.3 | 16.0 | 92.0 | 11.5 | 14.0 |
| 75 | 99.0 | 14.0 | 97.0 | 11.3 | 99.0 | 15.3 | 97.0 | 18.0 | 101.6 | 16.0 | 97.0 | 11.5 | 14.0 |
| 80 | 104.0 | 15.0 | 105.0 | 12.0 | 104.0 | 16.3 | 105.0 | 18.2 | 114.3 | 20.0 | 105.0 | 11.5 | 14.0 |
| 85 | 109.0 | 14.8 | 110.0 | 14.0 | 109.0 | 16.3 | 110.0 | 18.2 | 117.5 | 20.0 | 110.0 | 11.5 | 14.0 |
| 90 | 114.0 | 14.8 | 115.0 | 14.0 | 114.0 | 16.3 | 115.0 | 18.2 | 123.9 | 20.0 | 115.0 | 13.0 | 15.5 |
| 95 | 120.3 | 15.8 | 120.0 | 14.0 | 120.3 | 17.3 | 120.0 | 17.2 | 127.0 | 20.0 | 120.0 | 13.0 | 15.5 |
| 100 | 123.3 | 15.8 | 125.0 | 14.0 | 123.3 | 17.3 | 125.0 | 17.2 | 133.4 | 20.0 | 125.0 | 13.0 | 15.5 |

DE - ES - TR

Mating rings

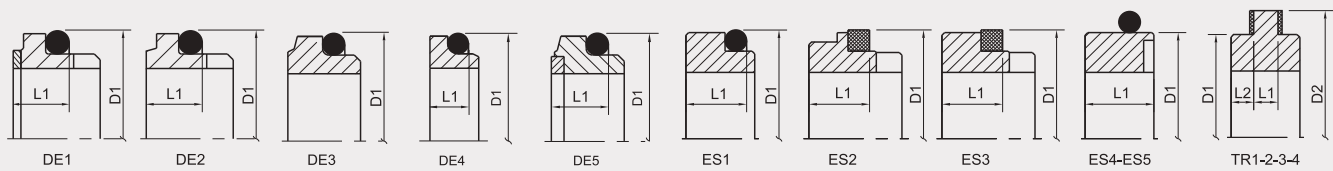

| DE1 - DE2 - DE3 - DE4 - DE5 | | | ES1 - ES2 - ES3 | | | ES4* | | | ES5* | |
|-----------------------------|-------|------|-----------------|-----|------|-------|-------|------|-------|------|
| d | D1 | L1 | d | D1 | L1 | d | D1 | L1 | D1 | L1 |
| 10 | 18.1 | 5.5 | 14 | 25 | 12.0 | .500 | 1.000 | .406 | 1.000 | .312 |
| 12 | 20.6 | 5.5 | 16 | 27 | 12.0 | .625 | 1.125 | .406 | 1.250 | .406 |
| 14 | 23.1 | 6.0 | 18 | 33 | 13.5 | .750 | 1.250 | .437 | 1.375 | .406 |
| 15 | 26.9 | 7.0 | 20 | 35 | 13.5 | .875 | 1.375 | .437 | 1.500 | .406 |
| 16 | 26.9 | 7.0 | 22 | 37 | 13.5 | 1.000 | 1.500 | .500 | 1.625 | .437 |
| 17 | 26.9 | 7.0 | 24 | 39 | 13.3 | 1.125 | 1.625 | .500 | 1.750 | .437 |
| 18 | 30.9 | 8.0 | 25 | 40 | 13.0 | 1.250 | 1.875 | .500 | 1.875 | .437 |
| 19 | 30.9 | 8.0 | 28 | 43 | 12.5 | 1.375 | 2.000 | .500 | 2.000 | .437 |
| 20 | 30.9 | 8.0 | 30 | 45 | 12.0 | 1.500 | 2.125 | .500 | 2.125 | .437 |
| 22 | 35.4 | 8.0 | 32 | 48 | 12.0 | 1.625 | 2.250 | .500 | 2.375 | .500 |
| 24 | 35.4 | 8.0 | 33 | 48 | 12.0 | 1.750 | 2.375 | .500 | 2.500 | .500 |
| 25 | 38.2 | 8.5 | 35 | 50 | 12.0 | 1.875 | 2.500 | .500 | 2.625 | .500 |
| 26 | 38.2 | 8.5 | 38 | 56 | 13.0 | 2.000 | 2.625 | .500 | 2.750 | .500 |
| 28 | 43.3 | 9.0 | 40 | 58 | 13.0 | 2.125 | 2.750 | .562 | 3.000 | .562 |
| 30 | 43.3 | 9.0 | 43 | 61 | 13.0 | 2.250 | 2.875 | .562 | 3.125 | .562 |
| 32 | 43.3 | 9.0 | 45 | 63 | 13.0 | 2.375 | 3.000 | .562 | 3.250 | .562 |
| 33 | 53.5 | 11.5 | 48 | 66 | 13.0 | 2.500 | 3.125 | .562 | 3.375 | .562 |
| 35 | 53.5 | 11.5 | 50 | 70 | 13.5 | 2.625 | 3.250 | .625 | 3.375 | .625 |
| 38 | 60.5 | 11.5 | 53 | 73 | 13.5 | 2.750 | 3.375 | .625 | 3.500 | .625 |
| 40 | 60.5 | 11.5 | 55 | 75 | 13.5 | 2.875 | 3.500 | .625 | 3.750 | .625 |
| 42 | 60.5 | 11.5 | 58 | 78 | 13.5 | 3.000 | 3.625 | .625 | 3.875 | .625 |
| 43 | 60.5 | 11.5 | 60 | 80 | 13.5 | 3.125 | 3.750 | .625 | 4.000 | .781 |
| 45 | 65.5 | 11.5 | 63 | 83 | 13.5 | 3.250 | 3.875 | .625 | 4.125 | .781 |
| 48 | 65.5 | 11.5 | 65 | 85 | 13.5 | 3.375 | 4.000 | .625 | 4.250 | .781 |
| 50 | 72.5 | 11.5 | 68 | 90 | 13.5 | 3.500 | 4.125 | .625 | 4.375 | .781 |
| 53 | 72.5 | 11.5 | 70 | 92 | 14.5 | 3.625 | 4.250 | .687 | 4.500 | .781 |
| 55 | 72.5 | 11.5 | 75 | 97 | 14.5 | 3.750 | 4.500 | .687 | 4.625 | .781 |
| 58 | 79.3 | 11.5 | 80 | 105 | 15.0 | 3.875 | 4.625 | .687 | 4.750 | .781 |
| 60 | 79.3 | 11.5 | 85 | 110 | 15.0 | 4.000 | 4.750 | .687 | 4.875 | .781 |
| 63 | 84.5 | 11.5 | 90 | 115 | 15.0 | | | | | |
| 65 | 84.5 | 11.5 | 95 | 120 | 15.0 | | | | | |
| 68 | 89.5 | 11.5 | 100 | 125 | 15.0 | | | | | |
| 70 | 89.5 | 11.5 | | | | | | | | |
| 75 | 94.5 | 11.5 | | | | | | | | |
| 80 | 99.5 | 11.5 | | | | | | | | |
| 85 | 105.5 | 13.5 | | | | | | | | |
| 90 | 111.5 | 13.5 | | | | | | | | |
| 95 | 116.5 | 13.5 | | | | | | | | |
| 100 | 119.5 | 13.5 | | | | | | | | |

| d (inc) | d (mm) | D1 | D2 | *TR1 | L1 | L2 | D1 | D2 | *TR2 | L1 | L2 | D1 | D2 | *TR3 | L1 | L2 | D1 | D2 | *TR4 | L1 | L2 |
|---------|--------|-------|-------|------|------|----|-------|-------|------|------|----|-------|-------|------|------|----|-------|-------|------|------|----|
| .750 | 18 | 1.370 | 1.750 | .250 | .250 | | 1.307 | 1.718 | .406 | .203 | | 1.426 | 1.850 | .315 | .189 | | - | - | - | - | |
| .875 | 20-22 | 1.494 | 1.875 | .250 | .250 | | 1.432 | 1.843 | .406 | .203 | | 1.551 | 1.948 | .315 | .189 | | - | - | - | - | |
| 1.000 | 24-25 | 1.620 | 2.000 | .375 | .250 | | 1.557 | 1.968 | .406 | .203 | | 1.676 | 2.067 | .315 | .189 | | - | - | - | - | |
| 1.125 | 28 | 1.745 | 2.125 | .375 | .250 | | 1.683 | 2.093 | .406 | .203 | | 1.990 | 2.480 | .437 | .313 | | 1.801 | 2.303 | .437 | .313 | |
| 1.250 | 30-32 | 1.870 | 2.250 | .375 | .250 | | 1.807 | 2.218 | .406 | .203 | | 2.115 | 2.598 | .437 | .313 | | 1.990 | 2.500 | .437 | .313 | |
| 1.375 | 33-35 | 1.995 | 2.375 | .375 | .250 | | 2.057 | 2.593 | .437 | .218 | | 2.240 | 2.717 | .437 | .313 | | 2.115 | 2.579 | .437 | .313 | |
| 1.500 | 38 | 2.245 | 2.625 | .375 | .250 | | 2.057 | 2.593 | .437 | .218 | | 2.490 | 2.992 | .437 | .313 | | 2.240 | 2.736 | .437 | .313 | |
| 1.625 | 40 | 2.370 | 2.750 | .375 | .250 | | 2.370 | 2.906 | .437 | .218 | | 2.615 | 3.110 | .437 | .313 | | 2.490 | 3.011 | .437 | .313 | |
| 1.750 | 43-45 | 2.495 | 3.000 | .375 | .250 | | 2.432 | 2.968 | .437 | .218 | | 2.740 | 3.228 | .437 | .313 | | 2.615 | 3.130 | .437 | .313 | |
| 1.875 | - | 2.620 | 3.125 | .375 | .250 | | 2.620 | 3.156 | .437 | .218 | | 2.865 | 3.386 | .437 | .313 | | 2.740 | 3.248 | .437 | .313 | |
| 2.000 | 48-50 | 2.745 | 3.250 | .375 | .250 | | 2.744 | 3.406 | .500 | .250 | | 3.115 | 3.740 | .563 | .374 | | 2.865 | 3.366 | .437 | .313 | |
| 2.125 | 53 | 2.870 | 3.500 | .375 | .250 | | 2.930 | 3.593 | .500 | .250 | | 3.240 | 3.858 | .563 | .374 | | 3.115 | 3.760 | .563 | .374 | |
| 2.250 | 55 | 2.995 | 3.625 | .375 | .250 | | 2.961 | 3.625 | .500 | .250 | | 3.365 | 3.976 | .563 | .374 | | 3.240 | 3.878 | .563 | .374 | |
| 2.375 | 58-60 | 3.120 | 3.750 | .375 | .250 | | 3.118 | 3.781 | .500 | .250 | | 3.490 | 4.173 | .563 | .374 | | 3.365 | 3.996 | .563 | .374 | |
| 2.500 | 63 | 3.245 | 4.000 | .375 | .250 | | 3.243 | 3.906 | .500 | .250 | | 3.610 | 4.252 | .563 | .374 | | 3.490 | 4.114 | .563 | .374 | |
| 2.625 | 65 | 3.370 | 4.125 | .375 | .250 | | 3.368 | 4.031 | .500 | .250 | | 3.740 | 4.370 | .563 | .374 | | 3.615 | 4.272 | .563 | .374 | |
| 2.750 | 68-70 | 3.615 | 4.250 | .750 | .250 | | 3.493 | 4.156 | .500 | .250 | | 3.865 | 4.488 | .563 | .374 | | 3.740 | 4.370 | .563 | .374 | |
| 2.875 | 73 | 3.740 | 4.375 | .750 | .250 | | 3.617 | 4.281 | .500 | .250 | | 3.927 | 4.526 | .563 | .374 | | 3.865 | 4.488 | .563 | .374 | |
| 3.000 | 75 | 3.865 | 4.500 | .750 | .250 | | 3.740 | 4.406 | .500 | .250 | | 4.053 | 4.685 | .563 | .374 | | 3.927 | 4.547 | .563 | .374 | |
| 3.125 | - | 3.990 | 4.625 | .750 | .250 | | 3.865 | 4.531 | .500 | .250 | | 4.240 | 4.921 | .563 | .374 | | 4.053 | 4.705 | .563 | .374 | |
| 3.250 | 80 | 4.115 | 4.750 | .750 | .250 | | 3.990 | 4.656 | .500 | .250 | | 4.490 | 5.118 | .563 | .374 | | 4.240 | 4.870 | .563 | .374 | |
| 3.375 | - | 4.240 | 4.875 | .750 | .250 | | 4.114 | 4.781 | .500 | .250 | | 4.615 | 5.276 | .563 | .374 | | 4.490 | 5.000 | .563 | .374 | |
| 3.500 | 85 | 4.365 | 5.000 | .750 | .250 | | 4.238 | 4.906 | .500 | .250 | | 4.740 | 5.354 | .563 | .374 | | 4.490 | 5.138 | .563 | .374 | |
| 3.625 | - | 4.490 | 5.125 | .750 | .250 | | 4.363 | 5.031 | .500 | .250 | | 4.865 | 5.511 | .563 | .374 | | 4.740 | 5.250 | .563 | .374 | |
| 3.750 | 90-95 | 4.615 | 5.250 | .750 | .250 | | 4.487 | 5.156 | .500 | .250 | | 4.990 | 5.591 | .563 | .374 | | 4.740 | 5.374 | .563 | .374 | |
| 3.875 | - | 4.740 | 5.375 | .750 | .250 | | 4.612 | 5.281 | .500 | .250 | | 5.115 | 5.767 | .563 | .374 | | 4.865 | 5.500 | .563 | .374 | |
| 4.000 | 100 | 4.865 | 5.500 | .750 | .250 | | 4.735 | 5.406 | .500 | .250 | | 5.240 | 5.866 | .563 | .374 | | 4.990 | 5.610 | .563 | .374 | |

BR - FR

Mating rings

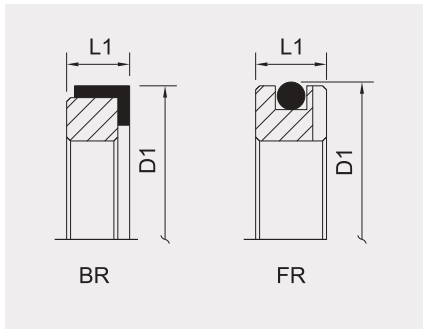

* upon request

| Seat | d | D1 | L1 |
|------|-------|-------|------|
| BR1 | 12 | 23.0 | 8.6 |
| BR1 | 14 | 25.0 | 8.6 |
| BR1 | 16 | 27.0 | 8.6 |
| BR1 | 18 | 33.0 | 10.0 |
| BR1 | 19 | 35.0 | 10.0 |
| BR1 | 20 | 35.0 | 10.0 |
| BR1 | 22 | 37.0 | 10.0 |
| BR1 | 24 | 39.0 | 10.0 |
| BR1 | 25 | 40.0 | 10.0 |
| BR1 | 28 | 43.0 | 10.0 |
| BR1 | 30 | 45.0 | 10.0 |
| BR1 | 32 | 48.0 | 10.0 |
| BR1 | 33 | 48.0 | 10.0 |
| BR1 | 35 | 50.0 | 10.0 |
| BR1 | 38 | 56.0 | 11.0 |
| BR1 | 40 | 58.0 | 11.0 |
| BR1 | 42 | 61.0 | 11.0 |
| BR1 | 43 | 61.0 | 11.0 |
| BR1 | 45 | 63.0 | 11.0 |
| BR1 | 48 | 66.0 | 11.0 |
| BR1 | 50 | 70.0 | 13.0 |
| BR1 | 53 | 73.0 | 13.0 |
| BR1 | 55 | 75.0 | 13.0 |
| BR1 | 58 | 78.0 | 13.0 |
| BR1 | 60 | 80.0 | 13.0 |
| BR1 | 63 | 83.0 | 13.0 |
| BR1 | 65 | 85.0 | 13.0 |
| BR1 | 68 | 90.0 | 15.3 |
| BR1 | 70 | 92.0 | 15.3 |
| BR1 | 75 | 97.0 | 15.3 |
| BR1 | 80 | 105.0 | 15.7 |
| BR1 | 85 | 110.0 | 15.7 |
| BR1 | 90 | 115.0 | 15.7 |
| BR1 | 95 | 120.0 | 15.7 |
| BR1 | 100 | 125.0 | 15.7 |
| BR1 | 70 | .875 | .312 |
| BR1 | 75 | 1.000 | .312 |
| BR1 | 80 | 1.250 | .406 |
| BR1 | 85 | 1.375 | .406 |
| BR2 | .375 | .875 | .312 |
| BR2 | .500 | 1.000 | .312 |
| BR2 | .625 | 1.250 | .406 |
| BR2 | .750 | 1.375 | .406 |
| BR2 | .812 | 1.375 | .406 |
| BR2 | .875 | 1.500 | .406 |
| BR2 | 1.000 | 1.625 | .437 |
| BR2 | 1.125 | 1.750 | .437 |
| BR2 | 1.187 | 1.875 | .437 |
| BR2 | 1.250 | 1.875 | .437 |
| BR2 | 1.375 | 2.000 | .437 |
| BR2 | 1.437 | 2.125 | .437 |
| BR2 | 1.500 | 2.125 | .437 |
| BR2 | 1.625 | 2.375 | .500 |

| Seat | d | D1 | L1 |
|------|-------|-------|------|
| BR2 | 2.000 | 2.750 | .500 |
| BR2 | 2.125 | 3.000 | .562 |
| BR2 | 2.250 | 3.125 | .562 |
| BR2 | 2.375 | 3.250 | .562 |
| BR2 | 2.500 | 3.375 | .562 |
| BR2 | 2.625 | 3.375 | .625 |
| BR2 | 2.750 | 3.500 | .625 |
| BR2 | 2.875 | 3.750 | .625 |
| BR2 | 3.000 | 3.875 | .625 |
| BR3 | .375 | .968 | .344 |
| BR3 | .500 | 1.094 | .343 |
| BR3 | .625 | 1.219 | .406 |
| BR3 | .750 | 1.344 | .406 |
| BR3 | .813 | 1.406 | .406 |
| BR3 | .875 | 1.469 | .406 |
| BR3 | 1.000 | 1.594 | .406 |
| BR3 | 1.125 | 1.875 | .472 |
| BR3 | 1.250 | 2.000 | .472 |
| BR3 | 1.375 | 2.125 | .472 |
| BR3 | 1.500 | 2.250 | .472 |
| BR3 | 1.625 | 2.375 | .472 |
| BR3 | 1.750 | 2.500 | .472 |
| BR3 | 1.875 | 2.625 | .472 |
| BR3 | 2.000 | 2.750 | .531 |
| BR3 | 2.125 | 2.875 | .531 |
| BR3 | 2.250 | 3.000 | .531 |
| BR3 | 2.375 | 3.125 | .531 |
| BR3 | 2.500 | 3.250 | .531 |
| BR3 | 2.625 | 3.625 | .625 |
| BR3 | 2.750 | 3.750 | .625 |
| BR3 | 2.875 | 3.875 | .625 |
| BR3 | 3.000 | 4.000 | .625 |
| BR4 | 10 | 21 | 5 |
| BR4 | 12 | 23 | 6 |
| BR4 | 14 | 25 | 6 |
| BR4 | 15 | 26 | 6 |
| BR4 | 16 | 27 | 6 |
| BR4 | 18 | 33 | 6 |
| BR4 | 20 | 35 | 6 |
| BR4 | 22 | 37 | 6 |
| BR4 | 24 | 39 | 6 |
| BR4 | 25 | 40 | 6 |
| BR4 | 28 | 43 | 6 |
| BR4 | 30 | 45 | 7 |
| BR4 | 32 | 48 | 7 |
| BR4 | 33 | 48 | 7 |
| BR4 | 35 | 50 | 8 |
| BR4 | 38 | 56 | 8 |
| BR4 | 40 | 58 | 8 |
| BR4 | 43 | 61 | 8 |
| BR4 | 45 | 63 | 8 |
| BR4 | 48 | 66 | 10 |
| BR4 | 50 | 70 | 10 |
| BR4 | 53 | 73 | 10 |
| BR4 | 55 | 75 | 10 |
| BR4 | 58 | 78 | 10 |
| BR4 | 60 | 80 | 12 |
| BR4 | 63 | 83 | 12 |
| BR4 | 65 | 85 | 12 |
| BR4 | 68 | 90 | 12 |
| BR4 | 70 | 92 | 12 |
| BR4 | 75 | 97 | 12 |
| BR5* | 10 | 24 | 7 |
| BR5* | 11 | 24 | 7 |
| BR5* | 12 | 26 | 7 |
| BR5* | 13 | 26 | 7 |
| BR5* | 14 | 28 | 7 |
| BR5* | 15 | 28 | 7 |

| Seat | d | D1 | L1 |
|------|-------|-------|------|
| BR5* | 18 | 35 | 8 |
| BR5* | 19 | 35 | 8 |
| BR5* | 20 | 38 | 8 |
| BR5* | 22 | 40 | 8 |
| BR5* | 25 | 44 | 9 |
| BR5* | 28 | 46 | 9 |
| BR5* | 30 | 50 | 9 |
| BR5* | 32 | 54 | 9 |
| BR5* | 35 | 58 | 10 |
| BR5* | 38 | 60 | 10 |
| BR5* | 40 | 64 | 10 |
| BR5* | 45 | 66 | 10 |
| BR5* | 50 | 72 | 10 |
| BR6 | 8a | 26.0 | 4.0 |
| BR6 | 8b | 22.0 | 4.0 |
| BR6 | 8c | 26.0 | 8.0 |
| BR6 | 9 | 26.0 | 8.0 |
| BR6 | 10 | 26.0 | 8.0 |
| BR6 | 11 | 26.0 | 8.0 |
| BR6 | 12a | 26.0 | 5.5 |
| BR6 | 12b | 26.0 | 8.0 |
| BR6 | 12c | 35.0 | 8.0 |
| BR6 | 13 | 26.0 | 8.0 |
| BR6 | 14a | 25.0 | 7.0 |
| BR6 | 14b | 28.5 | 8.0 |
| BR6 | 14c | 29.5 | 8.0 |
| BR6 | 14d | 35.0 | 8.0 |
| BR6 | 14e | 30.0 | 8.0 |
| BR6 | 15a | 29.5 | 8.0 |
| BR6 | 15b | 38.0 | 8.0 |
| BR6 | 15c | 38.0 | 8.0 |
| BR6 | 16a | 29.5 | 8.0 |
| BR6 | 16b | 38.0 | 8.0 |
| BR6 | 16c | 38.0 | 8.0 |
| BR6 | 16d | 42.0 | 8.0 |
| BR6 | 17 | 42.0 | 8.0 |
| BR6 | 18 | 42.0 | 8.0 |
| BR6 | 19 | 42.0 | 8.0 |
| BR6 | 20a | 42.0 | 8.0 |
| BR6 | 20b | 45.0 | 10.0 |
| BR6 | 22 | 45.0 | 10.0 |
| BR6 | 23 | 50.0 | 10.0 |
| BR6 | 24 | 50.0 | 10.0 |
| BR6 | 25a | 50.0 | 10.0 |
| BR6 | 25b | 50.0 | 10.0 |
| BR6 | 26 | 50.0 | 10.0 |
| BR6 | 28 | 57.0 | 10.0 |
| BR6 | 30 | 57.0 | 10.0 |
| BR6 | 32 | 57.0 | 10.0 |
| BR6 | 35 | 63.0 | 10.0 |
| BR6 | 38 | 68.0 | 12.0 |
| BR6 | 40 | 68.0 | 12.0 |
| BR6 | 45 | 73.0 | 12.0 |
| BR6 | 50 | 88.0 | 15.0 |
| BR6 | 55 | 88.0 | 15.0 |
| BR6 | 60 | 110.0 | 15.0 |
| BR6 | 65 | 110.0 | 15.0 |
| BR6 | 70 | 110.0 | 15.0 |
| BR7* | .437 | 1.175 | .250 |
| BR7* | .625 | 1.187 | .343 |
| BR7* | .750 | 1.312 | .281 |
| BR7* | .875 | 1.437 | .265 |
| BR7* | 1.000 | 1.625 | .406 |
| BR7* | 1.125 | 1.875 | .437 |
| BR7* | 1.187 | 1.750 | .437 |
| BR7* | 1.250 | 2.000 | .437 |
| BR7* | 1.375 | 2.125 | .437 |
| BR7* | 1.500 | 2.250 | .437 |

BR - FR

Mating rings

| Seat | d | D1 | L1 |
|------|-------|-------|------|
| BR7* | 2.125 | 3.000 | .625 |
| BR8* | .625 | 1.375 | .406 |
| BR8* | .750 | 1.275 | .281 |
| BR8* | .875 | 1.562 | .406 |
| BR8* | 1.000 | 1.750 | .437 |
| BR8* | 1.125 | 1.875 | .437 |
| BR8* | 1.250 | 1.762 | .365 |
| BR8* | 1.500 | 2.156 | .437 |
| BR8* | 1.625 | 2.312 | .500 |
| BR8* | 1.750 | 2.625 | .500 |
| BR9* | .500 | .938 | .225 |
| BR9* | .500 | 1.000 | .187 |
| BR9* | .500 | 1.000 | .218 |
| BR9* | .500 | 1.000 | .290 |
| BR9* | .625 | 1.187 | .288 |
| BR9* | .625 | 1.250 | .250 |
| BR9* | .625 | 1.250 | .281 |
| BR9* | .625 | 1.250 | .343 |
| BR9* | .625 | 1.270 | .406 |
| BR9* | .625 | 1.375 | .562 |
| BR9* | .750 | 1.375 | .250 |
| BR9* | .750 | 1.375 | .281 |
| BR9* | .750 | 1.437 | .406 |
| BR9* | .750 | 1.500 | .250 |
| BR9* | 1.000 | 1.625 | .385 |
| BR9* | 1.250 | 1.750 | .365 |

*upon request

| Seat | d | D1 | L1 |
|------|-------|-------|------|
| FR1 | .375 | .875 | .312 |
| FR1 | .500 | 1.000 | .312 |
| FR1 | .625 | 1.250 | .406 |
| FR1 | .750 | 1.375 | .406 |
| FR1 | .875 | 1.500 | .406 |
| FR1 | .937 | 1.562 | .437 |
| FR1 | 1.000 | 1.625 | .437 |
| FR1 | 1.125 | 1.750 | .437 |
| FR1 | 1.250 | 1.875 | .437 |
| FR1 | 1.375 | 2.000 | .437 |
| FR1 | 1.437 | 2.125 | .437 |
| FR1 | 1.500 | 2.125 | .437 |
| FR1 | 1.625 | 2.375 | .500 |
| FR1 | 1.750 | 2.500 | .500 |
| FR1 | 1.875 | 2.625 | .500 |
| FR1 | 2.000 | 2.750 | .500 |
| FR1 | 2.125 | 3.000 | .562 |
| FR1 | 2.250 | 3.125 | .562 |
| FR1 | 2.375 | 3.250 | .562 |
| FR1 | 2.500 | 3.375 | .562 |
| FR1 | 2.625 | 3.375 | .625 |
| FR1 | 2.750 | 3.500 | .625 |
| FR1 | 2.875 | 3.750 | .625 |
| FR1 | 3.000 | 3.875 | .625 |
| FR1 | 3.125 | 4.000 | .781 |
| FR1 | 3.250 | 4.125 | .781 |
| FR1 | 3.375 | 4.250 | .781 |
| FR1 | 3.500 | 4.375 | .781 |
| FR1 | 3.625 | 4.500 | .781 |
| FR1 | 3.750 | 4.625 | .781 |
| FR1 | 3.875 | 4.750 | .781 |
| FR1 | 4.000 | 4.875 | .781 |
| FR2 | .375 | .968 | .343 |
| FR2 | .500 | 1.094 | .343 |
| FR2 | .625 | 1.219 | .406 |
| FR2 | .750 | 1.344 | .406 |
| FR2 | .813 | 1.406 | .406 |
| FR2 | .875 | 1.469 | .406 |

| Seat | d | D1 | L1 |
|---------|-------|-------|------|
| FR2 | 1.000 | 1.594 | .406 |
| FR2 | 1.125 | 1.875 | .472 |
| FR2 | 1.250 | 2.000 | .472 |
| FR2 | 1.375 | 2.125 | .472 |
| FR2 | 1.500 | 2.250 | .472 |
| FR2 | 1.625 | 2.375 | .472 |
| FR2 | 1.750 | 2.500 | .472 |
| FR2 | 1.875 | 2.625 | .472 |
| FR2 | 2.000 | 2.750 | .531 |
| FR2 | 2.125 | 2.875 | .531 |
| FR2 | 2.250 | 3.000 | .531 |
| FR2 | 2.375 | 3.125 | .531 |
| FR2 | 2.500 | 3.250 | .531 |
| FR2 | 2.625 | 3.625 | .625 |
| FR2 | 2.750 | 3.750 | .625 |
| FR2 | 2.875 | 3.875 | .625 |
| FR2 | 3.000 | 4.000 | .625 |
| FR2 | 3.125 | 4.375 | .781 |
| FR2 | 3.250 | 4.500 | .781 |
| FR2 | 3.375 | 4.625 | .781 |
| FR2 | 3.500 | 4.750 | .781 |
| FR2 | 3.625 | 4.875 | .781 |
| FR2 | 3.750 | 5.000 | .781 |
| FR2 | 3.875 | 5.125 | .781 |
| FR2 | 4.000 | 5.250 | .781 |
| FR3 | 1.125 | 1.875 | .437 |
| FR3 | 1.250 | 2.000 | .437 |
| FR3 | 1.375 | 2.125 | .437 |
| FR3 | 1.437 | 2.250 | .437 |
| FR3 | 2.125 | 2.875 | .562 |
| FR3 | 2.500 | 3.250 | .562 |
| FR4 - 5 | 12a | 26.0 | 5.5 |
| FR4 - 5 | 12b | 26.0 | 8.0 |
| FR4 - 5 | 12c | 35.0 | 8.0 |
| FR4 - 5 | 13 | 26.0 | 8.0 |
| FR4 - 5 | 14a | 25.0 | 7.0 |
| FR4 - 5 | 14b | 28.5 | 8.0 |
| FR4 - 5 | 14c | 29.5 | 8.0 |
| FR4 - 5 | 14d | 35.0 | 8.0 |
| FR4 - 5 | 14e | 30.0 | 8.0 |
| FR4 - 5 | 15a | 29.5 | 8.0 |
| FR4 - 5 | 15b | 38.0 | 8.0 |
| FR4 - 5 | 15c | 38.0 | 8.0 |
| FR4 - 5 | 16a | 29.5 | 8.0 |
| FR4 - 5 | 16b | 38.0 | 8.0 |
| FR4 - 5 | 16c | 38.0 | 8.0 |
| FR4 - 5 | 16d | 42.0 | 8.0 |
| FR4 - 5 | 17 | 42.0 | 8.0 |
| FR4 - 5 | 18 | 42.0 | 8.0 |
| FR4 - 5 | 19 | 42.0 | 8.0 |
| FR4 - 5 | 20a | 42.0 | 8.0 |
| FR4 - 5 | 20b | 45.0 | 10.0 |
| FR4 - 5 | 22 | 45.0 | 10.0 |
| FR4 - 5 | 23 | 50.0 | 10.0 |
| FR4 - 5 | 24 | 50.0 | 10.0 |
| FR4 - 5 | 25a | 50.0 | 10.0 |
| FR4 - 5 | 25b | 50.0 | 10.0 |
| FR4 - 5 | 26 | 50.0 | 10.0 |
| FR4 - 5 | 28 | 57.0 | 10.0 |
| FR4 - 5 | 30 | 57.0 | 10.0 |
| FR4 - 5 | 32 | 57.0 | 10.0 |
| FR4 - 5 | 35 | 63.0 | 10.0 |
| FR4 - 5 | 38 | 68.0 | 12.0 |
| FR4 - 5 | 40 | 68.0 | 12.0 |
| FR4 - 5 | 45 | 73.0 | 12.0 |
| FR4 - 5 | 50 | 88.0 | 15.0 |
| FR4 - 5 | 55 | 88.0 | 15.0 |
| FR4 - 5 | 60 | 110.0 | 15.0 |
| FR4 - 5 | 65 | 110.0 | 15.0 |
| FR4 - 5 | 70 | 110.0 | 15.0 |

| Seat | d | D1 | L1 |
|------|-------|-------|------|
| FR6 | .437 | 1.175 | .250 |
| FR6 | .625 | 1.187 | .343 |
| FR6 | .750 | 1.187 | .406 |
| FR6 | 1.125 | 1.812 | .437 |
| FR6 | 1.437 | 2.063 | .437 |
| FR6 | 1.500 | 2.312 | .437 |
| FR6 | 1.625 | 2.625 | .500 |
| FR6 | 1.750 | 2.312 | .500 |
| FR6 | 1.875 | 2.687 | .500 |
| FR6 | 2.000 | 3.000 | .500 |
| FR6 | 2.500 | 3.250 | .437 |
| FR6 | 2.875 | 3.750 | .562 |
| FR6 | 3.125 | 4.000 | .625 |
| FR6 | 3.250 | 4.125 | .625 |
| FR6 | 3.375 | 4.250 | .625 |
| FR6 | 3.500 | 4.375 | .625 |
| FR6 | 3.625 | 4.500 | .687 |
| FR6 | 3.750 | 4.625 | .687 |
| FR6 | 3.875 | 4.750 | .687 |
| FR6 | 4.000 | 4.875 | .687 |
| FR7 | 1.000 | 1.750 | .437 |
| FR7 | 1.375 | 2.000 | .687 |
| FR7 | 1.437 | 2.250 | .375 |
| FR7 | 1.500 | 2.125 | .500 |
| FR7 | 1.750 | 2.625 | .500 |
| FR7 | 2.500 | 3.000 | .562 |
| FR7 | 2.750 | 3.625 | .625 |
| FR7 | 3.000 | 4.000 | .500 |
| FR8 | 1.437 | 2.250 | .625 |
| FR8* | 1.500 | 2.063 | .437 |
| FR8 | 1.750 | 2.750 | .625 |
| FR9 | 1.437 | 2.312 | .357 |

*upon request

AU

Mating rings

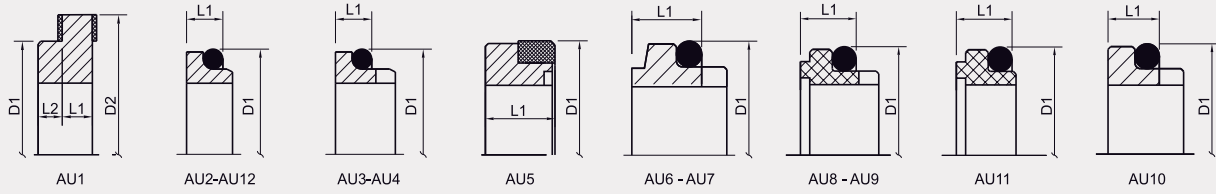

| d (inc) | AU1* | | | | AU4* | | AU5* | | AU2* - AU3* | | | AU6* - AU7* - AU10* | | | | AU8 - AU9 - AU11* | | | | AU12* | | |
|---------|-------|-------|------|------|---------|------|-------|------|-------------|-------|------|---------------------|---------|-----|----|-------------------|---------|-------|------|--------|-------|------|
| | D1 | D2 | L1 | L2 | d (inc) | L1 | D1 | L1 | d (mm) | D1 | L1 | d (mm) | d (inc) | D1 | L1 | d | d (inc) | D1 | L3 | d (mm) | D1 | L1 |
| .375 | - | - | - | - | .375 | .261 | | | 10 | 21.0 | 8.6 | 20 | .750 | 35 | 13 | 16 | - | 28.6 | 9.0 | 10 | 24.6 | 8.7 |
| .500 | - | - | - | - | .500 | .261 | 1.000 | .312 | 12 | 23.0 | 8.6 | 22 | - | 37 | 13 | 18 | - | 31.8 | 9.0 | 12 | 27.8 | 8.7 |
| .625 | - | - | - | - | .625 | .297 | 1.250 | .406 | 14 | 25.0 | 8.6 | 24 | .875 | 39 | 13 | 20 | - | 33.3 | 9.0 | 14-16 | 31.0 | 10.3 |
| .750 | 1.370 | 1.750 | .250 | .250 | .750 | .297 | 1.375 | .406 | 16 | 27.0 | 8.6 | 25 | 1.000 | 40 | 13 | 22 | - | 34.9 | 9.0 | 18-19 | 34.2 | 10.3 |
| .875 | 1.494 | 1.875 | .250 | .250 | .813 | .297 | 1.500 | .406 | 18 | 33.0 | 10.0 | 28 | 1.125 | 43 | 13 | 25 | - | 39.7 | 10.0 | 20 | 35.7 | 10.3 |
| 1.000 | 1.620 | 2.000 | .375 | .250 | .875 | .297 | 1.625 | .437 | 19 | 35.0 | 10.0 | 30 | - | 45 | 13 | 28 | - | 42.9 | 10.0 | 22 | 37.3 | 10.3 |
| 1.125 | 1.745 | 2.125 | .375 | .250 | 1.000 | .297 | 1.750 | .437 | 20 | 35.0 | 10.0 | 32 | 1.250 | 48 | 13 | 30 | - | 44.4 | 10.0 | 24-25 | 40.5 | 10.3 |
| 1.250 | 1.870 | 2.250 | .375 | .250 | 1.125 | .297 | 1.875 | .437 | 22 | 37.0 | 10.0 | 33 | - | 48 | 13 | 32 | - | 46.0 | 10.0 | 28 | 47.6 | 12.0 |
| 1.375 | 1.995 | 2.375 | .375 | .250 | 1.250 | .297 | 2.000 | .437 | 24 | 39.0 | 10.0 | 35 | 1.375 | 50 | 13 | 33 | - | 46.0 | 10.0 | 30-32 | 50.8 | 12.0 |
| 1.500 | 2.245 | 2.625 | .375 | .250 | 1.375 | .297 | 2.125 | .437 | 25 | 40.0 | 10.0 | 38 | 1.500 | 56 | 13 | 35 | - | 49.2 | 10.0 | 33 | 53.9 | 12.0 |
| 1.625 | 2.370 | 2.750 | .375 | .250 | 1.437 | .297 | 2.375 | .500 | 28 | 43.0 | 10.0 | 40 | - | 58 | 13 | 38 | - | 52.4 | 10.0 | 35 | 53.9 | 12.0 |
| 1.750 | 2.495 | 3.000 | .375 | .250 | 1.500 | .297 | 2.500 | .500 | 30 | 45.0 | 10.0 | 42 | - | 61 | 13 | 40 | - | 54.0 | 10.0 | 38 | 57.2 | 12.0 |
| 1.875 | 2.620 | 3.125 | .375 | .250 | 1.625 | .335 | 2.625 | .500 | 32 | 48.0 | 10.0 | 43 | 1.625 | 61 | 13 | 42 | - | 55.6 | 10.0 | 40 | 60.3 | 12.0 |
| 2.000 | 2.745 | 3.250 | .375 | .250 | 1.750 | .335 | 2.750 | .500 | 33 | 48.0 | 10.0 | 45 | 1.750 | 63 | 13 | 43 | - | 55.6 | 10.0 | 42-45 | 63.5 | 12.0 |
| 2.125 | 2.870 | 3.500 | .375 | .250 | 1.875 | .335 | 3.000 | .562 | 35 | 50.0 | 10.0 | 48 | 1.875 | 66 | 13 | 45 | - | 58.7 | 10.0 | 48 | 66.7 | 12.0 |
| 2.250 | 2.995 | 3.625 | .375 | .250 | 2.000 | .335 | 3.125 | .562 | 38 | 56.0 | 11.0 | 50 | 2.000 | 70 | 13 | 48 | - | 63.5 | 10.0 | 50 | 69.8 | 13.5 |
| 2.375 | 3.120 | 3.750 | .375 | .250 | 2.125 | .375 | 3.250 | .562 | 40 | 58.0 | 11.0 | 53 | 2.125 | 73 | 13 | 50 | - | 65.1 | 10.0 | 53 | 73.0 | 13.5 |
| 2.500 | 3.245 | 4.000 | .375 | .250 | 2.250 | .375 | 3.375 | .562 | 42 | 61.0 | 11.0 | 55 | - | 75 | 13 | - | 2.000 | 66.7 | 10.0 | 55 | 76.2 | 13.5 |
| 2.625 | 3.370 | 4.125 | .375 | .250 | 2.375 | .375 | 3.375 | .625 | 43 | 61.0 | 11.0 | 58 | 2.250 | 78 | 16 | 55 | - | 69.9 | 10.0 | 58-60 | 79.4 | 13.5 |
| 2.750 | 3.615 | 4.250 | .750 | .250 | 2.500 | .375 | 3.500 | .625 | 45 | 63.0 | 11.0 | 60 | 2.375 | 80 | 16 | 58 | - | 73.0 | 10.0 | 63 | 82.5 | 13.5 |
| 2.875 | 3.740 | 4.375 | .750 | .250 | 2.625 | .375 | 3.750 | .625 | 48 | 66.0 | 11.0 | 63 | 2.500 | 84 | 16 | 60 | - | 76.2 | 10.0 | 65 | 92.1 | 15.9 |
| 3.000 | 3.865 | 4.500 | .750 | .250 | 2.750 | .375 | 3.875 | .625 | 50 | 70.0 | 13.0 | 65 | - | 85 | 16 | 63 | - | 79.4 | 10.0 | 70 | 95.2 | 15.9 |
| 3.125 | 3.990 | 4.625 | .750 | .250 | 2.875 | .473 | 4.000 | .781 | 53 | 73.0 | 13.0 | - | 2.625 | - | - | 65 | - | 81.0 | 10.0 | 73 | 98.4 | 15.9 |
| 3.250 | 4.115 | 4.750 | .750 | .250 | 3.000 | .473 | 4.125 | .781 | 55 | 75.0 | 13.0 | 68 | - | 90 | 16 | 68 | - | 82.6 | 10.0 | 75 | 101.6 | 15.9 |
| 3.375 | 4.240 | 4.875 | .750 | .250 | 3.125 | .473 | 4.250 | .781 | 58 | 78.0 | 13.0 | 70 | 2.750 | 92 | 16 | 70 | - | 85.7 | 10.0 | - | 111.1 | 19.8 |
| 3.500 | 4.365 | 5.000 | .750 | .250 | 3.250 | .473 | 4.375 | .781 | 60 | 80.0 | 13.0 | - | 2.875 | - | - | 73 | - | 88.9 | 10.0 | 80 | 114.3 | 19.8 |
| 3.625 | 4.490 | 5.125 | .750 | .250 | 3.375 | .473 | 4.500 | .781 | 63 | 83.0 | 13.0 | 75 | 3.000 | 97 | 16 | 75 | - | 90.5 | 10.0 | 85 | 117.5 | 19.8 |
| 3.750 | 4.615 | 5.250 | .750 | .250 | 3.500 | .473 | 4.625 | .781 | 65 | 85.0 | 13.0 | 80 | 3.125 | 105 | 16 | - | 3.000 | 95.3 | 10.0 | - | 120.7 | 19.8 |
| 3.875 | 4.740 | 5.375 | .750 | .250 | 3.625 | .513 | 4.750 | .781 | 68 | 90.0 | 15.3 | - | 3.250 | - | - | 80 | - | 98.4 | 10.0 | 90 | 123.8 | 19.8 |
| 4.000 | 4.865 | 5.500 | .750 | .250 | 3.750 | .513 | 4.875 | .781 | 70 | 92.0 | 15.3 | 85 | 3.375 | 110 | 16 | - | 3.250 | 101.6 | 10.0 | 95 | 127.0 | 19.8 |
| | | | | | | | | | 75 | 97.0 | 15.3 | 90 | 3.500 | 115 | 16 | 85 | - | 104.8 | 10.0 | - | 130.2 | 19.8 |
| | | | | | | | | | 80 | 105.0 | 15.7 | - | 3.625 | - | - | - | 3.500 | 108.0 | 10.0 | 100 | 133.4 | 19.8 |
| | | | | | | | | | 85 | 110.0 | 15.7 | 95 | 3.750 | 120 | 16 | 90 | - | 109.5 | 10.0 | | | |
| | | | | | | | | | 90 | 115.0 | 15.7 | - | 3.875 | - | - | 95 | - | 114.3 | 10.0 | | | |
| | | | | | | | | | 95 | 120.0 | 15.7 | 100 | 4.000 | 125 | 16 | 100 | - | 119.0 | 10.0 | | | |
| | | | | | | | | | 100 | 125.0 | 15.7 | - | - | - | - | - | 4.000 | 123.8 | 10.0 | | | |

*upon request

UK - RU - NL

Mating rings

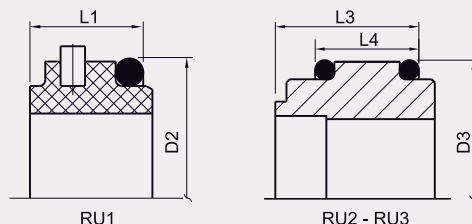
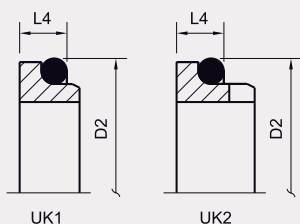

| UK1* - UK2* | | |
|-------------|-----|----|
| d | D2 | L4 |
| 8 | - | - |
| 10 | 21 | 7 |
| 12 | 23 | 7 |
| 14 | 25 | 7 |
| 15 | - | - |
| 16 | 27 | 7 |
| 17 | - | - |
| 18 | 33 | 10 |
| 19 | - | - |
| 20 | 35 | 10 |
| 22 | 37 | 10 |
| 24 | 39 | 10 |
| 25 | 40 | 10 |
| 26 | - | - |
| 28 | 43 | 10 |
| 30 | 45 | 10 |
| 32 | 48 | 10 |
| 33 | 48 | 10 |
| 35 | 50 | 10 |
| 38 | 56 | 13 |
| 40 | 58 | 13 |
| 42 | - | - |
| 43 | 61 | 13 |
| 45 | 63 | 13 |
| 48 | 66 | 13 |
| 50 | 70 | 14 |
| 53 | 73 | 14 |
| 55 | 75 | 14 |
| 58 | 78 | 14 |
| 60 | 80 | 14 |
| 63 | 83 | 14 |
| 65 | 85 | 14 |
| 68 | 90 | 16 |
| 70 | 92 | 16 |
| 75 | 97 | 16 |
| 80 | 105 | 18 |
| 85 | 110 | 18 |
| 90 | 115 | 18 |
| 95 | 120 | 18 |
| 100 | 125 | 18 |

| RU1* | | | RU2* - RU3* | | | | |
|-------|-------|-----|-------------|---------|-----|----|----|
| d | D1 | L1 | d (mm) | d (inc) | D3 | L3 | L4 |
| 1.000 | 1.500 | .81 | 20 | .750 | 42 | 23 | 18 |
| 1.125 | 1.875 | .81 | 22 | - | 44 | 23 | 18 |
| 1.187 | 1.937 | .81 | 24 | .875 | 46 | 23 | 18 |
| 1.250 | 2.000 | .81 | 25 | 1.000 | 47 | 23 | 18 |
| 1.375 | 2.125 | .81 | 28 | 1.125 | 50 | 23 | 18 |
| 1.437 | 2.187 | .81 | 30 | - | 52 | 23 | 18 |
| 1.500 | 2.250 | .81 | 32 | 1.250 | 54 | 23 | 18 |
| 1.625 | 2.375 | .81 | 33 | - | 55 | 23 | 18 |
| 1.750 | 2.500 | .81 | 35 | 1.375 | 57 | 23 | 18 |
| 1.875 | 2.625 | .81 | 38 | 1.500 | 64 | 25 | 20 |
| 2.000 | 2.750 | .81 | 40 | - | 66 | 25 | 20 |
| 2.125 | 2.875 | .81 | 42 | - | 69 | 25 | 20 |
| 2.250 | 3.000 | .81 | 43 | 1.625 | 69 | 25 | 20 |
| 2.375 | 3.125 | .81 | 45 | 1.750 | 71 | 25 | 20 |
| 2.500 | 3.250 | .81 | 48 | 1.875 | 74 | 25 | 20 |
| 2.625 | 3.375 | .81 | 50 | 2.000 | 76 | 25 | 20 |
| 2.750 | 3.500 | .81 | 53 | 2.125 | 79 | 25 | 20 |
| 2.875 | 3.625 | .81 | 55 | - | 81 | 25 | 20 |
| 3.000 | 3.750 | .81 | 58 | 2.250 | 89 | 28 | 22 |
| 3.125 | 4.062 | .81 | 60 | 2.375 | 91 | 28 | 22 |
| 3.250 | 4.187 | .81 | 63 | 2.500 | 94 | 28 | 22 |
| 3.375 | 4.312 | .81 | 65 | - | 96 | 28 | 22 |
| 3.500 | 4.437 | .81 | - | 2.625 | - | - | - |
| 3.625 | 4.562 | .81 | 68 | - | 99 | 30 | 24 |
| 3.750 | 4.687 | .81 | 70 | 2.750 | 101 | 30 | 24 |
| 3.875 | 4.812 | .81 | - | 2.875 | - | - | - |
| 4.000 | 4.937 | .81 | 75 | 3.000 | 110 | 30 | 24 |
| 4.250 | 5.187 | .81 | 80 | 3.125 | 115 | 31 | 25 |
| 4.500 | 5.437 | .81 | - | 3.250 | - | - | - |
| | | | 85 | 3.375 | 120 | 31 | 25 |
| | | | 90 | 3.500 | 125 | 31 | 25 |
| | | | - | 3.625 | - | - | - |
| | | | 95 | 3.750 | 130 | 31 | 25 |
| | | | - | 3.875 | - | - | - |
| | | | 100 | 4.000 | 135 | 31 | 25 |

*upon request

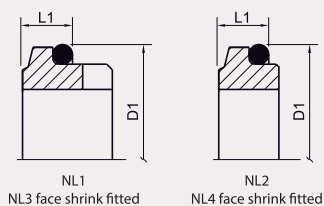

| NL1 - NL2 - NL3 - NL4 | | | | | |
|-----------------------|----|----|-----|-----|----|
| d | D2 | L2 | d | D2 | L2 |
| 10 | 21 | 7 | 43 | 61 | 13 |
| 12 | 23 | 7 | 45 | 63 | 13 |
| 14 | 25 | 7 | 48 | 66 | 13 |
| 15 | 27 | 7 | 50 | 70 | 14 |
| 16 | 27 | 7 | 53 | 73 | 14 |
| 18 | 33 | 10 | 55 | 75 | 14 |
| 19 | 35 | 10 | 58 | 78 | 14 |
| 20 | 35 | 10 | 60 | 80 | 14 |
| 22 | 37 | 10 | 63 | 83 | 14 |
| 24 | 39 | 10 | 65 | 85 | 14 |
| 25 | 40 | 10 | 68 | 90 | 16 |
| 28 | 43 | 10 | 70 | 92 | 16 |
| 30 | 45 | 10 | 75 | 97 | 16 |
| 32 | 48 | 10 | 80 | 105 | 18 |
| 33 | 48 | 10 | 85 | 110 | 18 |
| 35 | 50 | 10 | 90 | 115 | 18 |
| 38 | 56 | 13 | 95 | 120 | 18 |
| 40 | 58 | 13 | 100 | 125 | 18 |



a brand of MeccanotecnicaUmbraGroup

